

METAL DOORS & FRAMES



ANSI/NAAMM HMMA 865-13
February 27, 2013

GUIDE SPECIFICATIONS
FOR SOUND CONTROL
HOLLOW METAL DOOR
AND FRAME ASSEMBLIES

FOURTH EDITION

ANSI/NAAMM HMMA 865-13
February 27, 2013



METAL DOORS & FRAMES



Approval of an American National Standard requires verification by ANSI that the requirements for due process, consensus, and other criteria for approval have been met by the standards developer.

Consensus is established when, in the judgment of the ANSI Board of Standards Review, substantial agreement has been reached by directly and materially affected interests. Substantial agreement means much more than a simple majority, but not necessarily unanimity. Consensus requires that all views and objections be considered, and that a concerted effort be made toward their resolution.

The use of American National Standards is completely voluntary; their existence does not in any respect preclude anyone, whether they have approved the standards or not, from manufacturing, marketing, purchasing or using products, processes, or procedures not conforming to the standards.

The American National Standards Institute does not develop standards and will in no circumstances give an interpretation of any American National Standard. Moreover, no person shall have the right or authority to issue an interpretation of an American National Standard in the name of the American National Standards Institute. Requests for interpretation should be addressed to the sponsor whose name appears on the title page of this Standard.

CAUTION NOTICE: This American National Standard may be revised or withdrawn at any time. The procedures of the American National Standards Institute require that action be taken periodically to reaffirm, revise, or withdraw this Standard. Purchasers of American National Standards may receive current information on all standards by calling or writing the American National Standards Institute.

This standard was developed by representative members of and approved by the Hollow Metal Manufacturers Association Division (HMMA) of the National Association of Architectural Metal Manufacturers (NAAMM) to provide their opinion and guidance on the specification and use of swinging sound control hollow metal doors and frames. This standard contains advisory information only and is published as a public service by NAAMM and its HMMA Division.

NAAMM AND ITS HMMA DIVISION DISCLAIM ALL LIABILITY OF ANY KIND FOR THE USE, APPLICATION OR ADAPTATION OF MATERIAL PUBLISHED IN THIS STANDARD.

Current information on all NAAMM Standards is available by calling, writing, or visiting the website of the National Association of Architectural Metal Manufacturers, www.naamm.org.

National Association of Architectural Metal Manufacturers

800 Roosevelt Road, Building C, Suite 312

Glen Ellyn, IL 60137

Tel: 1-630-942-6591 • Fax: 1-630-790-3095

www.naamm.org

TABLE OF CONTENTS

Foreword	ii
Part 1 - GENERAL	
1.01 Summary	1
1.02 Products Provided Under This Section	1
1.03 Related Sections	1
1.04 References	2
1.05 Testing and Performance	3
1.06 Quality Assurance	4
1.07 Submittals	4
Part 2 - PRODUCTS	
2.01 Sound Control Hollow Metal Doors	5
2.02 Sound Control Panels	7
2.03 Sound Control Hollow Metal Door Frame Product	7
2.04 Manufacturing Tolerances	11
2.05 Hardware	11
2.06 Finish	12
Part 3 - EXECUTION	
3.01 Site Storage and Protection of Materials	12
3.02 Installation	13
3.03 Field Verification	14
3.04 Maintenance	15
Figures	16
Appendix (Not part of the Standard)	
Steel Tables, HMMA 803	A1
Grouting of Hollow Metal Frames, HMMA 820 TN01	A2
Standards Writing or Accreditation Organizations	A3
Over-View of ASTM Sound Control Tests	A4

FOREWORD

These specifications have been prepared in accordance with the CSI recommended Master Format 2012 with Part 1 - General, Part 2 - Product and Part 3 - Execution. Guide specifications are intended to be used as the basis for developing project specifications and must be edited to fit specific project requirements. Inapplicable provisions should be deleted, appropriate selections should be made where there are choices, and provisions applicable to the project should be added where necessary. Options are shown in brackets. Notes, recommendations and instructions to Specifiers are given in italics at the start of or directly following the sections to which they apply. Notes that contain permissive language are not considered part of the standard. Dates given with ASTM and other standards were current at the time this specification was published. When a more recent standard is available, the Specifier should verify its applicability to this Guide prior to its inclusion. *While the CSI Section Format locates Delivery, Storage and Handling in Part 1, NAAMM standards include them under Part 3 – Execution.*

This specification is comprehensive in regard to steel swinging sound control doors, door frames, sidelight, transom, borrowed light and fixed and operable window assemblies. It does not cover sliding sound control doors or other related components. Due to the complexity of the field of acoustics, it is advisable to retain an acoustical consultant or acoustician.

Materials and fabrication methods are specified in detail in Part 2. Specific internal door constructions are not covered since they are proprietary to each manufacturer. Pillowing of the door can occur on some acoustical doors due to the acoustical material used on the interior of the door. Pillowing should not exceed 1/2 inch (12.7 mm), this will not affect the acoustical quality of the door. Doors and frames manufactured in accordance with these specifications have successfully met the testing and performance requirements of Section 1.05. However, the materials and fabrication methods called for in these specifications, while providing an excellent guide, are not intended to restrict the use of other materials and methods where it can be demonstrated through the specific testing procedures in Section 1.05 that the construction can equal or exceed the performance levels specified. In order to ensure that a manufacturer's product meets the desired performance levels, the construction specifications must always include the Testing and Performance requirements of Section 1.05 and the Quality Assurance requirements of Section 1.06. Note: the effectiveness of a door and frame unit is dependent on the sum of all parts of the unit functioning effectively in order to meet the STC rating, OITC rating and/or STL specified. This means that all portions of the unit, including the door, frame, hinging and latching hardware, perimeter gaskets and glazing, are tested as a unit. All components must be supplied as tested; glazing may be factory or field installed.

The values stated in inch-pound units are to be regarded as the standard. Corresponding metric values are included in parenthesis for reference purposes only.

Hardware Considerations

The selection of the hardware is a very important part of a successful sound control assembly. Sound doors are generally heavier than conventional hollow metal doors, particularly in applications with higher ratings. Their weight can vary, from 4.5 to 22 lbs. per square foot (22 to 98 kg/m²), depending on the STC rating, OITC and/or STL and thickness of the door; therefore, it is important to specify proper heavy-duty hardware capable of handling the door weight over the life of the installation. A minimum of three traditional butt hinges or two cam-lift hinges is required for all units. The door frame may be manufactured from thicker materials than those of conventional hollow metal frames for doors weighing only 4.5 to 6 lbs. per square foot (22 to 30 kg/m²).

Sound control doors are built with specially designed proprietary cores. Any interference with this sound septum may cause a reduction in performance. Concealed vertical rod exit devices or concealed closers are examples of hardware that may interfere with the performance of the assembly.

Another important part of the assembly is the gasketing around the door. Hardware that may interfere with this seal should be avoided.

Other Key Considerations

Although many acoustic door frame assemblies closely resemble traditional hollow metal products, a number of additional factors must be taken into account.

- Installation instructions provided by the manufacturer must be followed in order to obtain the desired acoustical rating.
- The quality of the installation of the door, frame, gasketing and hardware is essential.
- The flatness of the floor beneath the door is critical.
- The manufacturer of sound control assemblies can provide advice on installation and hardware selection.

As is the case with any product that is certified based on performance done under controlled laboratory (STC) conditions, sound control door assemblies installed under less well-controlled job site (FSTC) conditions can be expected to have a 4 to 5 point reduction in STC performance.

Depending upon door and frame constructions, along with hardware and gasketing systems, sound control hollow metal door and window assemblies are available from NAAMM-HMMA members to suit a wide range of performance criteria. Specifiers are encouraged to consult member manufacturers for assistance with technical product information for your application.

For hollow metal doors and frames not requiring sound control hollow metal door assemblies give consideration to NAAMM HMMA 860, "Guide Specifications for Hollow Metal Doors and Frames" or ANSI/NAAMM HMMA 867, "Guide Specifications for Commercial Laminated Core Hollow Metal Doors and Frames". For commercial steel doors and frames expected to be subjected to a more rigorous level of use, ANSI/NAAMM HMMA 861, "Guide Specifications for Commercial Hollow Metal Doors and Frames", may be used. For situations where corrosion resistance beyond that of typical commercial steel door and frame applications, or where specialized aesthetic appearance are significant design criteria, consideration should be given to ANSI/NAAMM HMMA 866, "Guide Specifications for Stainless Steel Hollow Metal Doors and Frames". If security is a factor, there are two hollow metal standards available - ANSI/NAAMM HMMA 862, "Guide Specifications for Commercial Security Hollow Doors and Frames" and ANSI/NAAMM HMMA 863, "Guide Specifications for Detention Security Hollow Metal Doors and Frames".

CSI SECTION 08 34 73

SOUND CONTROL HOLLOW METAL DOOR AND FRAME ASSEMBLIES

PART 1 - GENERAL

1.01 SUMMARY

This Section includes swinging sound control doors, frames, transoms, sidelights, borrowed lights and window assemblies as shown in the contract documents.

1.02 PRODUCTS PROVIDED UNDER THIS SECTION

- A. Provide complete assemblies with door, frame and other material required of the manufacturer to obtain the specified Sound Transmission Classification (STC) rating, Outdoor-Indoor Transmission Classification (OITC) rating and/or Sound Transmission Loss (STL).
 - 1. Hollow Metal Sound Control Doors, swinging type, including [glass moldings and stops] [gasketing] [other], as shown in the approved submittal drawings.
 - 2. Hollow metal sound control panels, fixed or removable, similar in construction to hollow metal sound control doors, as shown in the approved submittal drawings.
 - 3. Hollow metal sound control frames, transom frames, sidelight, borrowed light and window assemblies, including [moldings and stops for fixed glazed openings] [cam lift hinges] [gasketing] [other], as shown in the approved submittal drawings.
 - 4. Hollow metal sound control sidelight, borrowed light and window assemblies with operable glazed lights, as shown in the approved submittal drawings.

In this guide specification the term "frame product" is used to define, as a group; frames, transom frames, fixed or operable sidelight, borrowed light and window assemblies.

1.03 RELATED SECTIONS

- A. Section 01 66 00 - Product Storage and Handling Requirements
- B. Section 03 30 00 - Cast-In-Place Concrete
- C. Section 04 20 00 - Unit Masonry
- D. Section 05 10 00 - Structural Metal Framing (for Lintels, Posts, Columns or Other Load Bearing Elements)
- E. Section 06 11 00 - Wood Framing
- F. Section 08 11 13 - Hollow Metal Doors and Frames
- G. Section 08 11 19 - Stainless Steel Doors and Frames
- H. Section 08 34 53 - Security Doors and Frames
- I. Section 08 71 00 - Door Hardware
- J. Section 08 80 00 - Glazing
- K. Section 09 20 00 - Plaster and Gypsum Board (for the Installation of Commercial Hollow Metal or Stainless Steel Doors and Frames in Steel Stud Partitions)
- L. Section 09 90 00 - Painting and Coating
- M. Section 11 19 00 - Detention Equipment
- N. Section ___ ___ ___ - Assembly of Knocked-Down or Slip-On Commercial Hollow Metal or Stainless Steel Frames
- O. Section ___ ___ ___ - Field Measurements

This specification covers only those products listed in Section 1.02. Not included in Section 08 34 73 are builders or rough hardware of any kind, weather-stripping, gaskets, items furnished by others, field painting and protection at the building site of products furnished under this section.

1.04 REFERENCES

The Standards listed in this Guide are referenced by basic designation only. The edition of a Standard is deemed as that in affect on the publication date this Guide, unless specifically noted otherwise. If a more recent standard is available, the Specifier should verify its applicability to this Guide prior to its inclusion.

- A. ANSI A250.10, Test Procedure and Acceptance Criteria for Prime Painted Steel Surfaces for Steel Doors and Frames
- B. ANSI/NAAMM HMMA 801, Glossary of Terms for Hollow Metal Doors and Frames
- C. ANSI/NFPA 80, Standard for Fire Doors and Other Opening Protectives
- D. ANSI/NFPA 105, Standard for the Installation of Smoke Door Assemblies and Other Opening Protectives
- E. ANSI/NFPA 252, Standard Methods of Fire Tests of Door Assemblies
- F. ANSI/NFPA 257, Standard Fire Test for Windows and Glass Block Assemblies
- G. ANSI/UL 9, Fire Tests of Window Assemblies
- H. ANSI/UL 10B, Fire Tests of Door Assemblies
- I. ANSI/UL 10C, Positive Pressure Fire Tests of Door Assemblies
- J. ANSI/UL 1784, Air Leakage Tests of Door Assemblies
- K. ASTM A 653/A 653M, Specification for Steel Sheet, Zinc-Coated, (Galvanized) or Zinc-Iron Alloy-Coated (Galvannealed) by the Hot-Dip Process
- L. ASTM A 1008/A 1008M, Specification for Steel, Sheet, Cold-Rolled, Carbon, Structural, High-Strength Low-Alloy and High-Strength Low-Alloy with Improved Formability. Solution Hardened and Bake Hardenable
- M. ASTM A 1011/A 1011M, Specification for Steel, Sheet and Strip, Hot-Rolled, Carbon, Structural, High-Strength Low-Alloy and High-Strength Low-Alloy with Improved Formability and Ultra-High Strength
- N. ASTM C 143/C 143M, Test Method for Slump of Hydraulic Cement Concrete
- O. ASTM E 90, Test Method for Laboratory Measurement of Airborne Sound Transmission Loss of Building Partitions and Elements
- P. ASTM E 336, Test Method for Measurement of Airborne Sound Insulation in Buildings
- Q. ASTM E 413, Classification for Rating of Sound Insulation
- R. ASTM E 966, Standard Guide for Field Measurements of Airborne Sound Insulation of Building Facades and Facade Elements
- S. ASTM E 1332, OITC, Outdoor Indoor Transmission Class
- T. CAN/ULC-S104, Standard Method for Fire Tests of Door Assemblies
- U. CAN4-S106, Standard Method for Fire Tests of Window and Glass Block Assemblies
- V. NAAMM HMMA 802, Manufacturing of Hollow Metal Doors and Frames
- W. NAAMM HMMA 803, Steel Tables
- X. NAAMM HMMA 810, Hollow Metal Doors
- Y. NAAMM HMMA 810, TN01 Defining Undercuts of Doors
- Z. NAAMM HMMA 820, Hollow Metal Frames
- AA. NAAMM HMMA 820 TN01, Grouting Hollow Metal Frames
- AB. NAAMM HMMA 820 TN02, Continuously Welded Frames
- AC. NAAMM HMMA 830, Hardware Selection for Hollow Metal Doors and Frames
- AD. NAAMM HMMA 831, Recommended Hardware Locations for Hollow Metal Doors and Frames
- AE. NAAMM HMMA 840, Guide Specifications for Installation and Storage of Hollow Metal Doors and Frames

AF. NAAMM HMMA 850, Fire-Rated Hollow Metal Doors and Frames

The following standards are used only for 'neutral pressure' fire test methods and should be deleted from project specifications when 'positive pressure' is required by the governing building code: ANSI/UL10B (H), CAN/ULC-S104 (T) and CAN4-S106 (U).

Conversely, ANSI/UL 10C (I) is used only for 'positive pressure' fire tests and should be deleted from project specifications requiring 'neutral pressure' fire tests.

ANSI/NFPA 252 (E), ANSI/NFPA 257 (F) and ANSI/UL 9 (G) reference both 'neutral pressure' and 'positive pressure' fire test methods and as such should be included in all project specifications, except those requiring compliance with Canadian Building Codes.

Only project specifications requiring compliance with Canadian Building Codes should include CAN/ULC-S104(T) and CAN4-S106 (U).

Refer to Appendix 3 for a list of the Standards Writing or Accreditation Organizations referenced in Section 1.04.

1.05 TESTING AND PERFORMANCE

- A. Conduct sound control performance testing on a fully operable assembly in accordance with ASTM E 90, ASTM E 413 and ASTM E 1332, by an independent testing laboratory. Qualify the laboratory referenced in the test report and/or certification under the National Voluntary Laboratory Accreditation Program (NVLAP) of the National Institute for Science and Technology (NIST) or the International Accreditation Service (IAS) under the International Laboratory Accreditation Cooperation (ILAC) agreement.

See Appendix 4 for an over-view of ASTM E 90, E 413, and ASTM E 1332.

- B. Labeled Fire-Rated and/or Smoke Control Door and Frame Product

1. Where determined and scheduled by the Architect;

- a. Provide Listed or Classified doors, panels, frames, transom frames, sidelight, borrowed light and window assemblies bearing the label of a testing agency having a factory inspection service for openings requiring fire protection and/or smoke control ratings.
- b. Test doors, panels, frames, transom frames and sidelight assemblies in accordance with [ANSI/NFPA 252 or ANSI/UL 10B or CAN/ULC-S104] [ANSI/NFPA 252 or ANSI/UL 10C] [and/or] [ANSI/UL 1784].
- c. Test borrowed light and window assemblies in accordance with [ANSI/UL9 or ANSI/NFPA 257] [CAN4-S106].
- d. Construct products as Listed or Classified for labeling.

ANSI/UL10C provides for positive pressure testing to accommodate the requirements of some jurisdictions and should be included only for such.

ANSI/UL10B, CAN/ULC-S104 and CAN4-S106 provide for 'neutral pressure' testing to accommodate the requirements of the remaining jurisdictions and should be included only for such.

ANSI/NFPA 252, ANSI/NFPA 257 and ANSI/UL 9 cover both neutral and positive pressure testing and therefore should be included in all project specifications, except when compliance with Canadian Building Codes is required.

ANSI/UL 1784 provides for smoke control assembly testing required by ANSI/NFPA 105 to accommodate these specific requirements and should be included only when required.

Include CAN/ULC-S104 and CAN4-S106 only for projects requiring conformance with Canadian Building Codes.

2. For any door or frame product specified by the Architect to be fire-rated, which cannot qualify for labeling due to design, hardware or other reason, advise the Architect, in the submittal

documents. Advise the Architect when hardware, glazing or other options specified, unknown at the time of submittal document preparation, affect fire labeling eligibility.

The Specifier must ensure that all performance based criteria such as fire-protection rating, temperature-rise rating, smoke control, STC, OITC and/or STL for each opening are clearly detailed by the Architect on the project door schedules.

STC and OITC ratings are specified as numeric values whereas STL should be specified as decibels within a critical frequency range for the offending sound (ie: 40 db minimum at 500 to 1250 Hz).

- C. Prime Paint Performance (ANSI A250.10)
 - 1. Sheet steel specimens, with the product manufacturer's production primer, replicating Finish 'as shipped', shall be tested in accordance with ANSI A250.10.
 - 2. Performance shall meet the Acceptance Criteria described in ANSI A250.10.
 - 3. Test Reports or Certificates of Compliance shall include a description of the test specimen, procedures used in testing, and indicate compliance with the contract document specified acceptance criteria.

1.06 QUALITY ASSURANCE

- A. Manufacturer's Qualifications
 - 1. Provide evidence of having personnel and plant equipment capable of fabricating sound control hollow metal door, frame and window assemblies of the types specified.
 - 2. Provide evidence of having a quality control system in place.
- B. Quality Criteria
 - 1. Compliance with Section 1.05 is required for all door and frame product provided under this Section.
 - 2. Fabricate in strict accordance with the approved submittal drawings.
 - 3. Meet fabrication methods and product quality standards set by the Hollow Metal Manufacturers Association, HMMA, a division of the National Association of Architectural Metal Manufacturers, NAAMM, as set forth in the contract documents and NAAMM's HMMA 800 through 850 Series documents.

1.07 SUBMITTALS

- A. Submittal Drawings
 - 1. Show dimensioned door and frame product elevations and sections.
 - 2. Show listing of opening descriptions including locations, material thicknesses and anchors.
 - 3. Show location and details of openings.
 - 4. Provide manufacturer's recommended installation instructions and procedures.
- B. Reports
 - 1. Submit accredited laboratory test reports or certifications that the assembly construction provided has been tested in accordance with Section 1.05.A of this specification.
- C. Contractor responsible for coordination and installation of products covered under this Section shall;
 - 1. Verify and provide to the manufacturer, actual opening sizes and site conditions by field measurements before fabrication. Coordinate field measurements with fabrication and construction schedules to avoid delays.
 - 2. Verify that substrate conditions, whether existing or installed under other Sections, are as detailed in the Architect's drawings and are acceptable for product installation in accordance with the manufacturer's instructions.
- D. Reflect measurements and conditions determined under Section 1.07.C in submittal documents and manufacture product accordingly.

- E. Do not proceed with fabrication without receipt of approved submittal drawings and approved hardware schedules.

The approved submittal drawings and the approved hardware schedule are the versions that have been provided to the hollow metal sound control door manufacturer at the time of release for fabrication. These drawings and the schedule are considered part of the project construction documents. Insist upon receiving detailed templates along with approved submittal drawings to assure proper coordination between Contractor and installers.

PART 2 - PRODUCTS

2.01 SOUND CONTROL HOLLOW METAL DOORS

A. Materials

1. Steel

- a. Cold-rolled steel conforming to ASTM A 1008/A 1008M, CS, Type B
- b. Hot-rolled, pickled and oiled (HRPO) steel conforming to ASTM A 1011/A 1011M, CS, Type B
- c. Zinc-coated steel conforming to ASTM A 653/A 653M, CS, Type B

2. Door Cores

- a. Manufacturer's standard internal construction of doors as required to meet the [STC rating], [OITC rating] and/or [STL] specified.

B. Construction

ANSI and ASTM Standards no longer utilize 'gage' to define steel thickness. In this Specification steel is expressed in terms of minimum decimal inch (millimeter) thickness. Dimensions or sizes traditionally expressed in fractional inches are shown in decimal inches (millimeters). HMMA has developed a series of Tables, (NAAMM HMMA 803) included as Appendix 1 of this Specification, to summarize the imperial standards and their corresponding metric values.

1. Fabricate door types, sizes and constructions in accordance with the contract documents and meeting the performance requirements of Section 1.05.
2. Door face sheet thickness as required to meet STC, OITC and/or STL specified but not less than 0.042 in. (1.06 mm).
 - a. Interior doors constructed of 0.042 in. (1.06 mm) minimum thickness commercial quality steel sheet, free of scale, pitting or surface defects, conforming to ASTM A 1008/A 1008M for cold-rolled steel, ASTM A 653/A 653M CS Type B Coating Designation A25 (ZF75) for zinc-coated steel, or ASTM A 1011/A 1011M CS Type B for hot-rolled pickled and oiled steel.

For interior areas subject to corrosive conditions it is recommended that zinc-coated face sheets, as specified in 2.01.B.2.b, be used.
 - b. Exterior door face sheets 0.042 in. (1.06 mm) minimum thickness zinc coated steel conforming to ASTM A 653/A 653M CS Type B Coating Designation G60 (Z180) or A60 (ZF180), free of scale, pitting or surface defects.
3. Door thickness as required to meet STC rating, OITC rating and/or STL specified.
4. Fabricate doors neat in appearance, with edge bends true, straight and of minimum radius for the thickness of metal used.
5. Prior to shipment mark each door with an identification number as shown on the approved submittal drawings.
6. Door construction as required by the door manufacturer to maintain contact with acoustical gaskets.

7. Provide top and bottom edges of doors as required by the door manufacturer to maintain contact with acoustical gaskets or to accommodate acoustical seals such as automatic door bottoms.
 - a. Close top and bottom of door with a continuous steel channel, not less than 0.053 in. (1.34 mm) thickness, welded or laminated to both face sheets.
8. Exterior doors and where otherwise scheduled by the Architect, close doors flush at the top edge with a steel closure channel. Where required for attachment of weather-stripping, provide a flush steel closure channel at the bottom edge with openings to permit the escape of entrapped moisture.

Sound attenuation performance is partly dependent upon the type of hardware and sound seals used. Coordination of this Section and the Door Hardware Section is required to avoid duplication of products and assure proper performance. Sound control doors are built with specially designed proprietary cores. Any interference with this sound septum may cause a reduction in performance. Concealed vertical rod exit devices or concealed closers are examples of hardware that may interfere with the performance of the assembly.

Sound control assemblies include the gasketing around the perimeter of the door. Hardware that interferes with this seal must be avoided. An experienced sound control door manufacturer can provide advice on the best hardware to use.

9. Hardware Reinforcements and Preparations
 - a. Hardware supplier to coordinate hardware compatibility with the sound door assembly manufacturer.
 - b. Advise the Architect in the submittal documents of any hardware preparations that compromise the sound control capabilities of the assembly prior to fabrication.
 - c. Mortise, reinforce, drill and tap doors at the factory for templated hardware only, in accordance with the approved hardware schedule and templates provided by the hardware supplier.
 - d. Weld all edge mounted hardware reinforcements to door.
 - e. Reinforce doors for surface mounted hardware, anchor hinges, thrust pivots, pivot reinforced hinges, continuous hinges or non-templated hardware. Drilling and tapping, by others in the field under Section ____.
 - f. Steel thickness for hardware reinforcements to be the manufacturer's standard as required to adequately support the door and hardware, but shall not be less than:
 - i. Full mortise hinges and pivots:..... 0.167 in. (4.24 mm) or 0.123 in. (3.12 mm) angle or channel shaped type
 - ii. Lock fronts, latching devices and strikes:..... 0.067 in. (1.70 mm) or 0.053 in. (1.34 mm) unitized reinforcement with extruded tapped holes that provide equivalent number of thread as 0.067 in (1.70 mm)
 - iii. Flush bolts: 0.067 in. (1.70 mm)
 - iv. Internal reinforcements for other surface applied hardware: 0.053 in. (1.34 mm)
 - g. Where electronic hardware is indicated on the approved hardware schedule, provide wire access from hinge edge to device in accordance with the templates provided.

10. Glazing Assemblies (if applicable)

Glass is relatively permeable to sound; therefore, the manufacturer's test results regarding allowable glazing material and sizes must be followed to retain sound retarding characteristics of the assembly.

- a. Where specified or scheduled, provide steel fixed glass molding and removable stop glazing assemblies, matching the material type of the door face sheets, as tested by the manufacturer for the model and sound rating specified, to secure glazing materials furnished by and installed [at the factory] [in the field by a qualified glazer under Section 08 80 00].
- b. Advise the Architect in the submittal documents if glazing specified or scheduled by the Architect compromises the sound control capabilities of the door prior to fabrication.
- c. When dual glazed systems are provided, each piece of glazing must be capable of being removed independently. Provide fixed glass molding or integral stops, located on the secure side of the door, as designated on the Architect's drawings and/or door schedules.
- d. Removable stops; Manufacturer's standard but not less than 0.032 in. (0.81 mm) steel, with butt or mitered corner joints, secured to the frame opening by cadmium or zinc coated screws.
- e. Prepare fire-rated doors for listed glazing materials in accordance with the sound control door and glazing manufacturer's listings.

Louvers are not permitted in sound control hollow metal door assemblies.

11. Operational Clearances

- a. Critical clearances between doors and frames, and between doors and thresholds/floors required for optimum assembly performance are to be specifically noted in the submittal documents and manufacturer's installation instructions/recommendations. Where fire-rated and/or smoke control doors are specified, clearances must comply with NFPA 80 and/or NFPA 105.

2.02 SOUND CONTROL HOLLOW METAL PANELS

- A. Fabricate panels of the same nominal thickness, materials and construction as specified in Section 2.01 and as tested by the manufacturer for the model and rating specified.
- B. Install [factory installed] [field installed by others in accordance with the door manufacturer's installation instructions].
- C. Finish as specified in Section 2.06.

2.03 SOUND CONTROL HOLLOW METAL FRAME PRODUCT

Provisions of this Section are applicable to frames, transoms, sidelights, borrowed lights and window assemblies, unless indicated otherwise.

A. Materials:

A sound control door is typically heavier than a commercial steel door of equal size and may require thicker frame and anchor materials. It is also important to consider this extra weight when designing and constructing the wall. Frame material type should match the door.

1. Steel

- a. Cold-rolled steel conforming to ASTM A 1008/A 1008M, CS, Type B
- b. Hot-rolled, pickled and oiled (HRPO) steel conforming to ASTM A 1011/A 1011M, CS, Type B
- c. Zinc-coated steel conforming to ASTM A 653/A 653M, CS, Type B

B. Construction:

1. Fabricate frame product as welded units of the sizes and types shown on the approved submittal drawings. Frame product shall be constructed in accordance with the contract documents and meet the performance criteria specified in Section 1.05. Knocked-down frames are not acceptable.
2. Profile thickness as required to meet STC rating, OITC rating and/or STL specified, but not less than 0.053 in. (1.34 mm).
 - a. Interior Frame Product: Construct profiles of commercial quality steel sheet, free of scale, pitting or surface defects, cold-rolled steel conforming to ASTM A 1008/A 1008M, zinc-coated steel conforming to ASTM A 653/A 653M CS Type B Coating Designation A25 (ZF75), or hot-rolled, pickled and oiled steel conforming to ASTM A 1011/A 1011M.

For interior areas subject to corrosive conditions it is recommended that zinc-coated frame product, as specified in 2.03.B.2.b be used.
 - b. Exterior Frame Product: Construct profiles of commercial quality zinc-coated steel sheet, free of scale, pitting or surface defects, conforming to ASTM A 653/A 653M CS Type B Coating Designation G60 (Z180) or A60 (ZF180).
3. Fabricate all finished work neat in appearance, square, and free of defects, warps or buckles, with pressed steel members straight and of uniform profile through their lengths.
4. Provide jamb, header, mullion and sill profiles in accordance with the frame schedule and as shown on the approved submittal drawings.
5. Welding
 - a. Perimeter Face Joints (flush or indented): Continuously welded internally or externally with flush face joints finished smooth with seamless faces.
 - b. The use of gussets or splice plates as a substitute for welding is not permitted.
 - c. Internal Flush Face Joints: Continuously welded and finished smooth with seamless faces.
 - d. Members at Internal Indented Intersections: Securely welded to concealed reinforcements, and have hairline face seams.
 - e. All Other Intersection Elements: Hairline seams.
6. When shipping limitations or site access so dictate, or when advised by the contractor responsible for coordination or installation, fabricate frame product for large openings sections, designated for assembly and welding in the field by others under Sections 06 11 00 or 09 20 00. Install alignment plates or angles at each joint of the same material and thickness as the frame, in accordance with approved submittal drawings. Weld joints, grind smooth and prime paint.
7. Prior to shipment mark frame product with an identification number as shown on the approved submittal drawings.
8. Hardware Reinforcements and Preparations
 - a. Hardware supplier to coordinate hardware compatibility with the sound door assembly manufacturer.
 - b. Advise the Architect in the submittal documents of any hardware preparations that compromise the sound control capabilities of the assembly prior to fabrication.

See Note under 2.01.B.8.
 - c. Mortise, reinforce, drill and tap frame product at the factory for templated hardware only, in accordance with the approved hardware schedule and templates provided by the hardware supplier.
 - d. Reinforce frame product for surface mounted hardware, anchor hinges, thrust pivots, continuous hinges or non-templated mortised hardware. Drilling and tapping, in the field under Section _____.
 - e. Weld all hardware reinforcements to frame product.

See NAAMM HMMA 830, "Hardware Selection for Hollow Metal Doors and Frames" for additional information.

- f. Minimum thickness of hardware reinforcements;
 - i. Full Mortise Hinges and Pivots: 0.167 in x 1.25 x 10 in. length (4.24 mm x 31.75 mm x 254 mm) or 0.123 in. (3.12 mm) thickness angle or channel shaped type
 - ii. Strikes: 0.093 in. (2.36 mm) or 0.053 in. (1.34 mm) unitized reinforcement with extruded tapped holes that provide equivalent number of threads as 0.093 in. (2.36 mm)
 - iii. Flush bolts, closers, and other surface applied hardware: 0.093 in. (2.36 mm)

- 9. Where electronic hardware is indicated on the Architect's drawings or approved hardware schedule, provide prepared grout guards in accordance with the templates provided. Fabricate access plates, where required, of the same material, thickness and finish as the frame product, fastened with corrosion resistant screws. Secure access plates with a minimum of four (4) #8-32 machine screws or #6 sheet metal screws, spaced at 12 in. (305 mm) on center maximum.

- 10. Floor Anchors
 - a. Weld floor anchors inside jambs. Provide two (2) holes for fasteners supplied and installed by others under Section [06 11 00] [09 20 00].
 - b. Thickness of floor anchors; same as frame, minimum.
 - c. Where specified or scheduled, provide adjustable floor anchors with no more than 2 in. (50.8 mm) height adjustment.
 - d. For applications that do not permit the use of a floor anchor, substitute an additional jamb anchor at a location not to exceed 8 in. (204 mm) from the base of the jamb.

- 11. Jamb Anchors
 - a. Provide frame product with anchorage appropriate to frame and wall construction.
 - b. Masonry Type

Provide steel adjustable jamb anchors of the strap and stirrup or T-strap type not less than 0.053 in. (1.34 mm) thickness or 0.156 in. (4 mm) diameter wire type, for frame product to be installed in new masonry walls. Straps; 2 in. x 10 in. (50 mm x 254 mm) in size minimum, corrugated and/or perforated. Place jamb anchors at a maximum of 18 in. (457 mm) from top and bottom of openings. Minimum number of anchors, spaced at maximum of 32 in. (813 mm) on center, provided on each jamb based on the over-all frame height:

 - i. Up to 60 in. (1524 mm) 2 anchors
 - ii. Greater than 60 in. (1524 mm) up to 90 in. (2286 mm) 3 anchors
 - iii. Greater than 90 in. (2286 mm) up to 96 in. (2438 mm) 4 anchors
 - iv. Greater than 96 in. (2438 mm) 4 anchors plus one (1) for each 24 in. (610 mm) or fraction thereof, spaced at 24 in. (610 mm) maximum between anchors

c. Drywall Type

Provide steel jamb anchors of suitable design, not less than 0.042 in. (1.06 mm) thickness, welded inside each jamb for frame product installed in drywall partitions. Place jamb anchors not greater than 18 in. (457 mm) from top and bottom of openings. Minimum number of anchors spaced at a maximum of 32 in. (813 mm) on center, provided on each jamb, based on the over-all frame height:

- i. Up to 60 in. (1524 mm) 3 anchors
- ii. Greater than 60 in. (1524 mm)
up to 90 in. (2286 mm) 4 anchors
- iii. Greater than 90 in. (2286 mm)
up to 96 in. (2438 mm) 5 anchors
- iv. Greater than 96 in. (2438 mm) 5 anchors plus 1 for each 24 in. (610 mm) or fraction thereof, spaced at 24 in. (610 mm) maximum between anchors

d. Expansion Bolt Type

Prepare frame product for installation in existing masonry or concrete walls for expansion bolt type anchors. Provide a countersunk or dimpled hole for a 0.375 in. (9.52 mm) diameter flat head bolt and a spacer welded within the frame profile. Locate anchors a maximum of 6 in. (152 mm) from the top and bottom of the frame, with intermediate spacing at a maximum of 26 in. (660 mm) on center. Bolts and shields for such anchors provided and installed by others under Section 06 11 00.

e. Other Anchor Types

Construct and provide frame product to be installed in pre-finished concrete, masonry, steel or stud partition openings, with anchoring systems of suitable design as shown on the approved submittal drawings. Fasteners for such anchors provided by others under Section [03 30 00] [04 20 00].

A pre-finished opening may be one that is constructed as part of another assembly or system (e.g., pre-cast concrete panel) and which requires anchors similar in performance to those covered by 2.03.B.11.b and d.

- 12. Fabricate frame product installed in masonry walls with door openings greater than 48 in. (1219 mm) in width with a steel channel or angle stiffener factory welded into the head. Provide stiffeners not less than 0.093 in. (2.36 mm) in thickness, not longer than the door opening width. Stiffeners and frame product are not to be used as lintels or load bearing members.
- 13. Attach grout guards fabricated from not less than 0.016 in. (0.40 mm) thick steel at hardware mortises on frame product to be grouted.
- 14. For all door openings in frame product provide a temporary steel spreader welded or mechanically attached to the base of the jambs or mullions to serve as bracing during shipping and handling. Spreaders are not to be used for installation.
- 15. Removable Glazing Stops
 - a. Where specified, provide removable glass stops to secure glazing material to frame product located on the non-secure side of the frame as designated on the Architect's drawings and/or schedules.
 - b. Fabricate removable glazing stops from steel channel, not less than 0.032 in. (0.81 mm), of the same material type specified for the frame product.
 - c. Treat the frame section underneath the glazing stops and the inside of the glazing stops for maximum paint adhesion and paint with a rust inhibitive primer prior to installation in the opening. Glazing stops fabricated from zinc-coated steel conforming to ASTM A 653/A 653M, A40 (ZF120) for interior frames, A60 (ZF180) or G60 (Z180) for exterior openings need not be primed on the inside.

2.04 MANUFACTURING TOLERANCES

The manufacturer of the doors and frames is responsible only for the manufacturing tolerances listed in Section 2.04.A. The final clearances and relationship between door and frame depend on the setting of the frame and the hanging and adjustment of the door and hardware (see Section 3.02).

A. Maintain manufacturing tolerances within the following limits:

1. Frame Product for Single door or Pair of Doors

- a. Width, measured between rabbets at the head: nominal opening width + 1/16 in. (1.58 mm), - 1/32 in. (0.79 mm)
- b. Height (total length of jamb rabbet): nominal opening height +1/16 in. (1.58 mm), - 1/32 in. (0.79 mm)
- c. Cross sectional profile dimensions;
 - i. Face ± 1/32 in. (0.79 mm)
 - ii. Stop ± 1/32 in. (0.79 mm)
 - iii. Rabbet ± 1/32 in. (0.79 mm)
 - iv. Depth ± 1/32 in. (0.79 mm)
 - v. Throat ± 3/32 in. (2.38 mm)

See Figure 1 of this guide for section profile tolerance details. Frames overlapping walls to have throat dimension 1/8 in. (3.17 mm) greater than dimensioned wall thickness to accommodate irregularities in wall construction.

2. Doors

- a. Width ± 3/64 in. (1.19 mm)
- b. Height ± 3/64 in. (1.19 mm)
- c. Thickness ±1/16 in. (1.58 mm)
- d. Edge Flatness 1/16 in. (1.58 mm) maximum
- e. Surface Flatness 1/8 in. (3.17 mm) maximum

Acoustical steel doors are undersized to fit the frame's door opening. Edge clearances are based upon individual manufacturer's designs.

3. Hardware

- a. Cutout dimensions Template dimensions + 0.015 in. (0.38 mm), -0
- b. Location ± 1/32 in. (0.79 mm)
- c. Between hinge centerlines ± 1/64 in. (0.4 mm)

2.05 HARDWARE

A. Locations of hardware on doors and frame product, as a standard, are listed below. All dimensions, except hinge locations, are referenced from the floor.

1. Hinges: A minimum of three (3) traditional butt hinges or two (2) cam-lift hinges is required for all units.
 - a. Top 5 in. (127 mm) from underside of frame rabbet at door opening to top of hinge
 - b. Bottom 10 in. (254 mm) from floor to bottom of hinge
 - c. Intermediate Centered between top and bottom hinges
2. Locks and latches 38 in. (965 mm) to centerline of knob or lever shaft
3. Deadlocks 46 in. (1168 mm) to centerline of cylinder

4. Exit hardware38 in. (965 mm) to centerline of cross bar or as shown on hardware template
5. Roller Latches45 in. (1143 mm) to centerline of latch

The hardware locations listed in this specification reflects HMMA's 830, "Hardware Selection for Hollow Metal Doors and Frames" and 831, "Recommended Hardware Locations for Hollow Metal Doors and Frames". However, specific hardware and/or individual door frame manufacturers' designs may require different locations.

B. Sill Condition:

1. The floor area under a sound control door must be flat, level, and smooth.
2. Where required for assembly compliance, furnish a smooth, flush [stainless steel] [aluminum] [hard surface] threshold for the door bottom to seal against when the door is in the closed position.

The sound door assembly manufacturer is not responsible for thresholds or floor conditions which prevent door bottom gasketing systems from providing the required acoustical seal. Consult the sound door manufacturer for guidance.

2.06 FINISH

- A. After fabrication, fill and sand all tool marks and surface imperfections as required to make face sheets, vertical edges and weld joints free from irregularities and dressed smooth.
- B. After appropriate metal preparation, exposed surfaces of door and frame product manufactured from cold-rolled, hot-rolled, A25 (ZF75), or G60 (Z180) zinc-coated steel shall receive a factory applied rust inhibitive primer which meets or exceeds the performance requirements of Section 1.05.C.
- C. All exposed surfaces of door and frame product manufactured from A40 (ZF120) or heavier zinc-coated galvanneal steel shall have areas where zinc coating has been removed during fabrication touched-up with a zinc-rich rust inhibitive primer or shall receive a factory applied full-coat rust inhibitive primer.
- D. All primer must be fully cured prior to shipment.

All primer and finish paint must be formulated for Direct to Metal (DTM) application. Some types of paint will not dry completely. It is imperative that the type of paint selected dries completely and results in a smooth, hard surface. If the wrong type of finish paint is used, the paint will become soft and sticky. This condition, called "plasticizer migration", occurs when solvents from uncured paint reacts with neoprene or vinyl gaskets, particularly with some latex paints. The problem appears to be the paints' slow release of solvent that dissolves out the plasticizer in the acoustical gaskets. To avoid this problem we recommend using a "low VOC" or "no VOC" finish paint. VOC stands for "volatile organic compound".

PART 3 - EXECUTION

3.01 SITE STORAGE AND PROTECTION OF ACOUSTICAL MATERIALS

Correct site storage and protection is essential to the proper performance of doors and frame product. The requirements for proper storage are given in the following sections. However, it is important to recognize that proper storage is not the responsibility of the sound control hollow metal manufacturer. For this reason the requirements for installation of hollow metal sound control doors and frames is in the section of the specifications where installation of work is specified, Section 01 66 00. For additional information regarding storage see NAAMM HMMA 840, "Guide Specification for Installation and Storage of Hollow Metal Doors and Frames".

- A. The contractor responsible for receiving sound control hollow metal product must remove all wraps or covers upon delivery at the building site and ensure that any scratches or disfigurement caused by shipping or handling are promptly cleaned and touched up with a rust inhibitive Direct-to-Metal (DTM) primer.
- B. The contractor responsible for receiving sound control hollow metal product shall ensure that materials are properly stored on planks or dunnage in a dry location. Doors and frame product must be stored in a vertical position, spaced by blocking. Store doors on their top edge, eliminating the potential of damage to the bottom seal. Cover all materials to protect them from damage but in such a manner as to permit air circulation.

Figure 2 of this guide illustrates recommended storage positioning. Refer to NAAMM-HMMA 840 for additional information.

3.02 INSTALLATION

Correct installation is essential to the proper performance of doors and frame product. The requirements for proper installation are given in the following Sections. However it is important to recognize that installation is not the responsibility of the hollow metal manufacturer. For this reason the requirements for installation should be included in Sections 03 30 00, 04 20 00, 06 11 00 and/or 09 20 00 of the project specifications, as appropriate. For additional information see NAAMM HMMA 840, "Guide Specifications for Installation and Storage of Hollow Metal Doors and Frames".

- A. The Installer is responsible for the following:
 - 1. Prior to installation, check the area of floor on which the frame product is to be installed and within the path of the door swing, for flatness and correct as necessary.
 - 2. Prior to installation, remove temporary spreaders. Check each door and frame product for correct size, swing, fire rating and opening number.
 - 3. Prior to installation, isolate and protect from grout and antifreeze agents, all interior surfaces of perimeter frame product sections to be installed in masonry or concrete walls.

The drawbacks and benefits associated with the use of water based masonry grouts, with or without antifreeze agents, should be carefully weighed during the detailing and specification process. Grouting of mullions and other closed sections is not recommended and plaster based grouts should not be used. Refer to NAAMM HMMA Tech Note, HMMA 820 TN01-03, "Grouting Hollow Metal Frames", included as Appendix 2, for further guidance.

- 4. During the setting of frame product check and correct as necessary for opening width, opening height, squareness, alignment, twist and plumbness. Maintain installation tolerances within the following limits:
 - a. Opening Width measured from rabbet to rabbet at top, middle and bottom of frame; + 1/16 in. (1.58 mm), - 1/32 in. (0.79 mm)
 - b. Opening Height measured vertically between the frame head rabbet and top of floor or bottom of frame minus jamb extensions at each jamb and across the head; + 1/16 in. (1.58 mm), - 1/32 in. (0.79 mm)
 - c. Squareness measured on a line from jamb, perpendicular to frame head; not to exceed 1/16 in. (1.58 mm)
 - d. Alignment measured at jambs on a horizontal line parallel to the plane of the face; not to exceed 1/16 in. (1.58 mm)
 - e. Twist measured at opposite face corners of jambs on parallel lines perpendicular to the plane of the door rabbet; not to exceed 1/16 in. (1.58 mm)
 - f. Plumbness..... measured at the jambs on a perpendicular line from the head to the floor; not to exceed 1/16 in. (1.58 mm)

The above tolerances provide a reasonable guideline for proper installation of steel frame product. However, it should be noted that the cumulative effect of the installation tolerances at or near their maximum levels could result in sufficient misalignment to prevent the door from functioning properly. Installers should be careful not to create a tolerance buildup. Tolerance buildup occurs when several tolerances are at or near their maximums. The details in Figure 3 illustrate methods of measuring the above specified tolerances.

5. Grout guards are intended to protect hardware mortises and tapped holes from masonry grout of 4 in. (101 mm) maximum slump consistency which is hand troweled in place. If a lighter consistency grout (greater than 4 in. (101 mm) slump when tested in accordance with ASTM C 143/C 143M) is to be used, special precautions must be taken in the field by the installer to protect the aforementioned.
6. Frame products are not intended or designed to act as forms for grout or concrete. Grout frame sections in "lifts" or take precautions to ensure that frames are not deformed or damaged by the hydraulic forces that occur during this process.
7. Keep steel surfaces free of grout, tar and/or other bonding materials or sealers. Promptly clean grout, tar, bonding materials or sealers off doors and frame product.
8. Installer to refinish to match original, any marks caused by spreader removal.
9. Exposed hollow metal surfaces which have been scratched or otherwise marred during installation, cleaning, and/or field welding, shall promptly be finished smooth, cleaned, treated for maximum paint adhesion and touched up with a rust inhibitive primer comparable to and compatible with the shop applied primer and finish paint specified in Section 09 90 00. All touch-up primer and finish paint must be formulated for Direct to Metal (DTM) application.
10. Install acoustic doors and frame product in accordance with the manufacturer's installation instructions, test reports and/or certifications.
11. Install labeled fire doors and frame product in accordance with the terms of their listings, ANSI/NFPA 80 or the local Authority Having Jurisdiction.
12. Install hardware in accordance with hardware manufacturer's templates and instructions.
13. Maintain proper door clearances in accordance with Section 2.01.B.11, except for special conditions otherwise noted. Where necessary, metal hinge shims, furnished by installer, are permitted to maintain clearances.
14. Install and adjust acoustical seals in accordance with the sound door manufacturer's installation instructions.
15. Install glazing materials in accordance with Section 08 80 00.
16. Finish paint in accordance with the sound door assembly and paint manufacturer's instructions and Section 09 90 00.
17. Sound door and frame product to be finished with a DTM (Direct-to-Metal) paint with a gloss rating not greater than 20% reflectance, measured using a 60 degree gloss meter.

Do not paint gasketing materials.

3.03 FIELD VERIFICATION (Optional)

- A. Engage a qualified representative approved by the manufacturer to:
 1. Inspect completed installation of a representative sample of door and frame assemblies.
 2. Test all components through a minimum of ten complete cycles of operation.
 3. Verify each component is correctly installed.
 4. Direct installer in adjusting components for correct operation.
 5. Issue certified statement of compliance of installed door and frame assemblies to Architect as per approved contract documents.

- B. At the request and expense of the Owner, an independent testing agency may:
 - 1. Test door and frame assemblies selected by Owner or Architect in accordance with ASTM E336 for interior applications and ASTM E966 for exterior assemblies.
 - 2. Issue certified report documenting compliance of installed door and frame assemblies to specified acoustical performance requirements.
 - 3. Notify Architect a minimum of four (4) calendar days prior to scheduled testing dates.

3.04 MAINTENANCE

- A. Instruct the owner's maintenance personnel regarding the operation and maintenance of these assemblies.

END OF SECTION

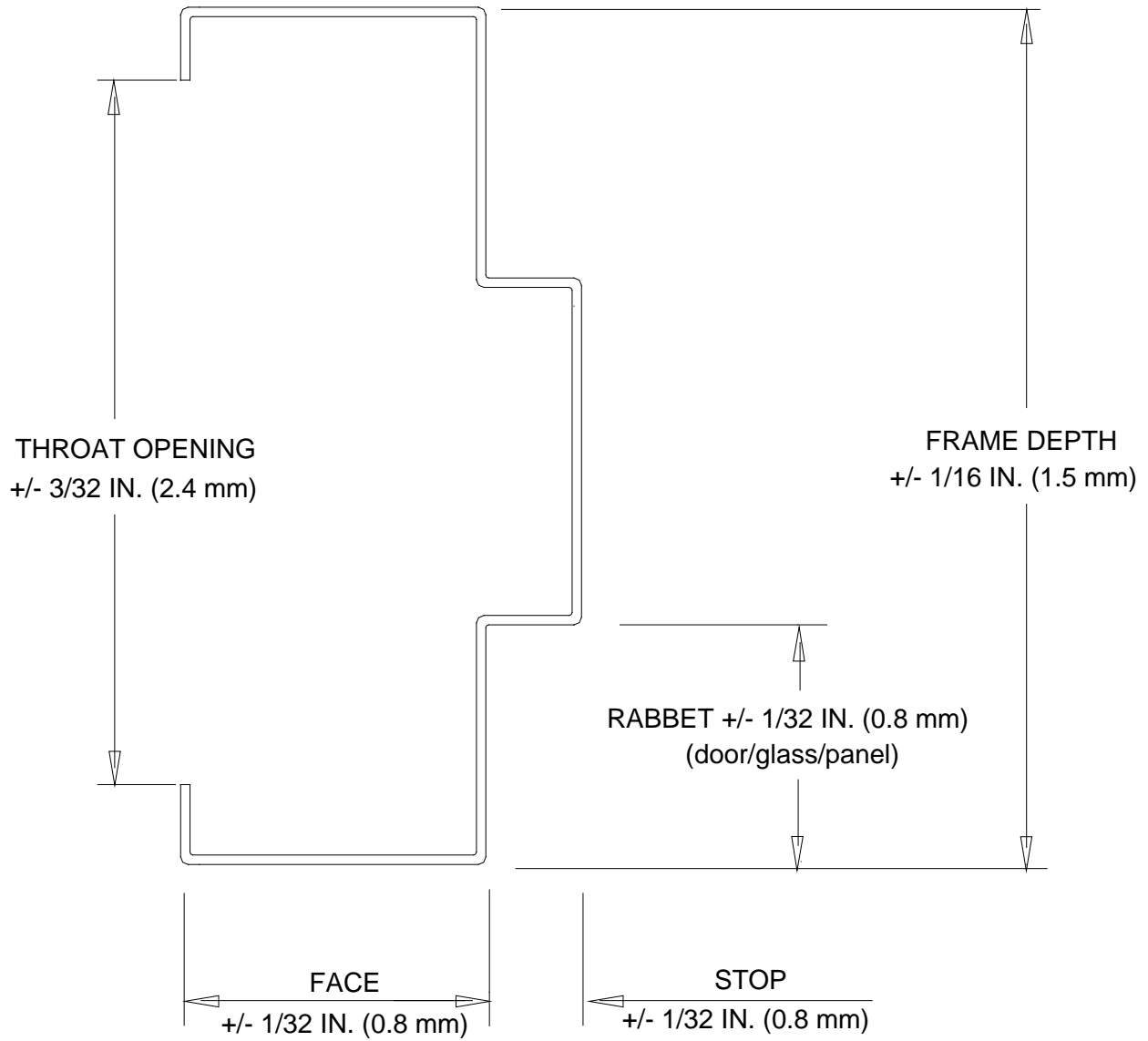

SECTIONAL PROFILE TOLERANCES

Figure 1

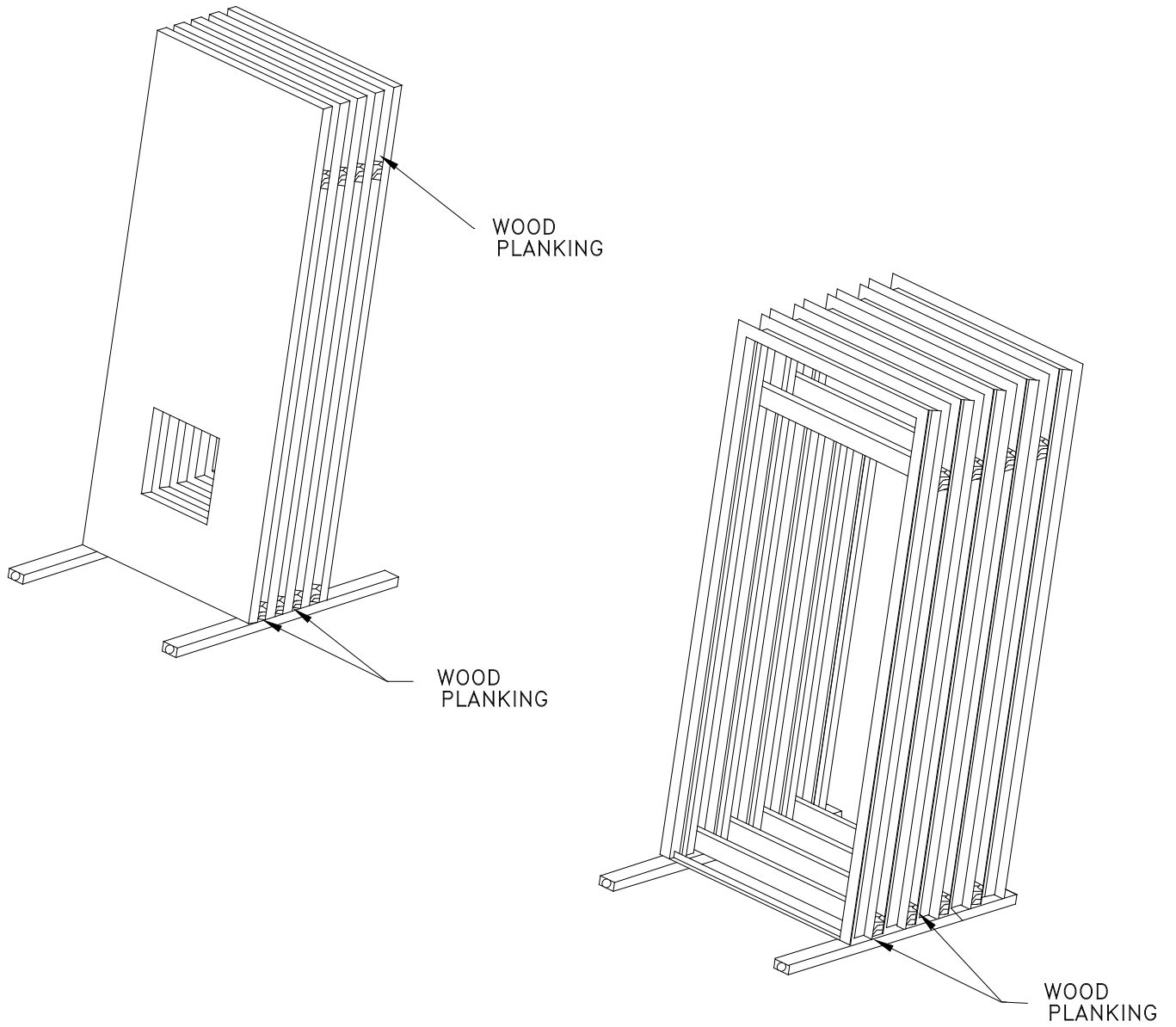

RECOMMENDED STORAGE

Figure 2

OPENING WIDTH; MEASURED HORIZONTALLY FROM RABBET TO RABBET AT TOP, MIDDLE AND BOTTOM OF FRAME; $\pm 1/16$ IN. (1.5mm)

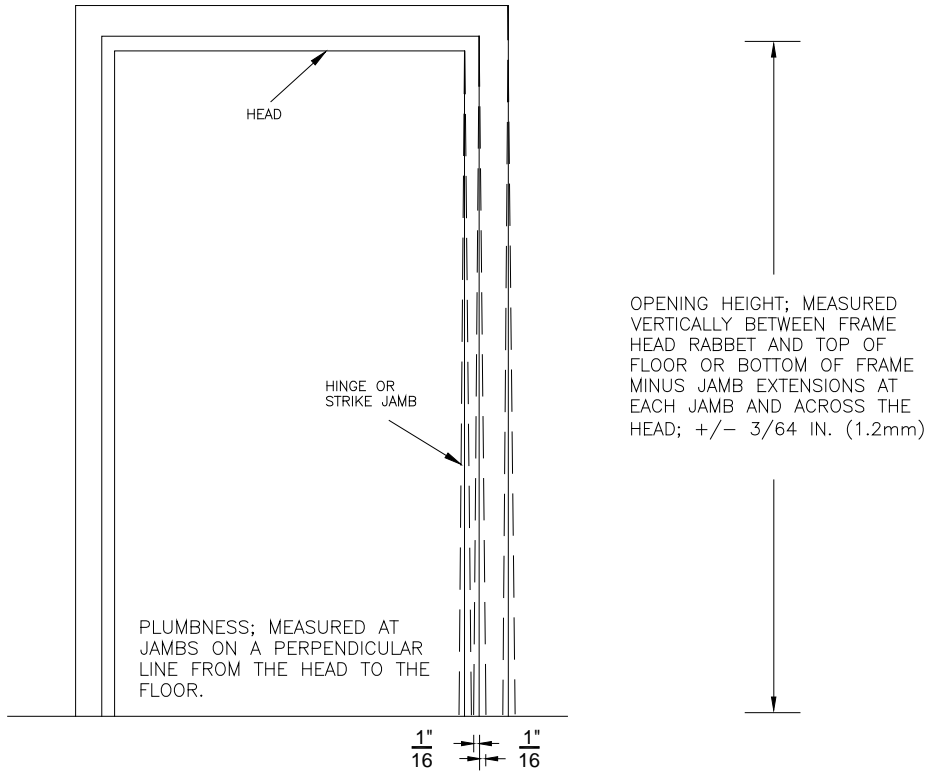
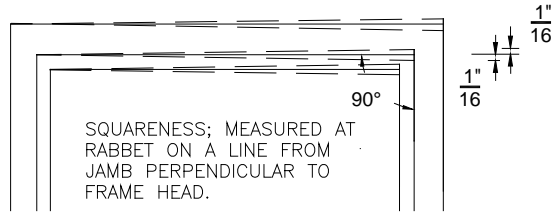

PROFILE MAY VARY AS A FUNCTIONAL DESIGN

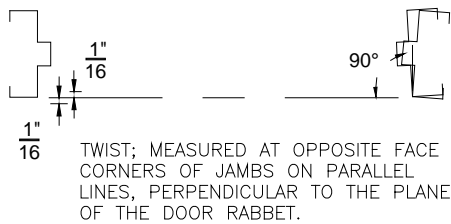
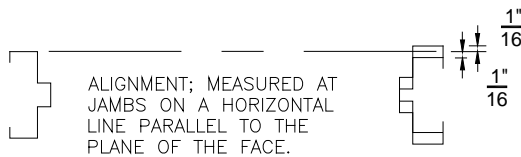

INSTALLATION TOLERANCES

Figure 3

APPENDIX 1

(Not part of the Standard)

NAAMM/HMMA 803-08 - STEEL TABLES

Prior to 1970, sheet steel was referred to by gage. ASTM and ANSI currently do not list gage numbers in their standards. Like many generic terms, gage (or gauge) is ingrained in many vocabularies and is misunderstood as a term for thickness. NAAMM is publishing this minimum thickness table to be used instead of discontinued gage numbers.

The decimal inch values shown were taken from the Underwriters Laboratories, Inc. publication for gage number and equivalent thickness. Corresponding metric values are included for reference purposes only.

MINIMUM THICKNESS (Uncoated Steel Sheet)		
Gage	Decimal Inch	mm
4	0.214	5.43
5	0.199	5.05
6	0.184	4.67
7	0.167	4.24
8	0.152	3.86
10	0.123	3.12
12	0.093	2.36
14	0.067	1.70
16	0.053	1.34
18	0.042	1.06
20	0.032	0.81
22	0.026	0.66
24	0.020	0.50
26	0.016	0.40
28	0.013	0.33

CONVERSION		
Fractional Inch	Decimal Inch	mm
	1.000	25.40
15/16	0.937	23.81
7/8	0.875	22.22
13/16	0.812	20.63
3/4	0.750	19.05
11/16	0.687	17.46
5/8	0.625	15.87
9/16	0.562	14.28
1/2	0.500	12.70
7/16	0.437	11.11
3/8	0.375	9.52
5/16	0.312	7.93
1/4	0.250	6.35
3/16	0.187	4.76
1/8	0.125	3.17
1/16	0.062	1.58

DISCLAIMER

This sheet was developed by representative members of the Hollow Metal Manufacturers Association Division (HMMA) of the National Association of Architectural Metal Manufacturers (NAAMM) to provide their opinion and guidance on minimum thickness and corresponding metric equivalents used for hollow metal doors and frames. This sheet contains advisory information only and is published as a public service by the HMMA Division.

NAAMM AND ITS HMMA DIVISION DISCLAIM ALL LIABILITY OF ANY KIND FOR THE USE,
APPLICATION OR ADAPTATION OF MATERIAL SHOWN ON THIS SHEET

APPENDIX 2

(Not part of the Standard)

GROUTING HOLLOW METAL FRAMES HMMA-820 TN01-03

Grout, when used in accordance with industry guidelines, can improve frame durability, sound deadening and, depending on wall construction, increases frame anchorage strength. Grouting of the frame does not increase door durability, nor is it required for fire-rated frames. For most commercial applications, grouting of mullions and other closed sections is not recommended.

For applications covered by ANSI/NAAMM HMMA 862, "Guide Specifications for Commercial Security Hollow Metal Doors and Frames" and ANSI/NAAMM HMMA 863, "Guide Specifications for Detention Security Hollow Metal Doors and Frames", the standards require that "frame jambs shall be fully grouted to provide added security protection against battering, wedging, spreading, and other means of forcing open the door".

Grout is a water-based product. If not used properly, it can destroy the opening in a very short time. Grout can be either "mortar", which is a masonry mixture of lime, cement, sand and water, or "plaster", a gypsum-based product.

Plaster grout dries with exposure to air. When a frame member is filled solid with plaster grout, only those areas exposed to air will dry and harden, while the center remains wet (uncured). The water remaining in the plaster grout can rust the frame from the inside.

Mortar grout cures by chemical reaction and hardens throughout. Use mortar grout.

Frames are not designed to act as forms for grout. Grout must have a maximum 4 in. slump and be hand troweled in place. Bracing of the frame may be necessary prior to grouting to prevent sagging of the header or bowing of the jamb due to weight or pressure of the grout. Grout should not be installed after gypsum wallboard is installed, as the liquid within the grout will deteriorate the wallboard.

When dictated by temperatures, anti-freezing agents for mortar may be recommended by specifications. These agents can adversely affect metal and all surfaces in contact with grout must be coated with a corrosion resistant material.

It is recommended that the contractor be responsible for the grouting and for any additional barrier coating. It is also the contractor's responsibility to use care in the application of the grout.

APPENDIX 3

(Not part of the Standard)

STANDARDS WRITING OR ACCREDITATION ORGANIZATIONS

- ANSI American National Standards Institute, Inc.
11 West 42nd Street
New York, NY 10036
Tel: (212) 642-4900
Website: www.ansi.org
- ASTM ASTM International
100 Barr Harbor Drive
West Conshohocken, PA 19428-2959
Tel: (610) 832-9585
Website: www.astm.org
- IAC International Accreditation Services
5360 Workman Mill Road
Whittier, CA 90601
Tel: (562) 364-8201
Website: www.iasonline.org
- ICC International Code Council
500 New Jersey Avenue NW
6th Floor
Washington, DC 20001-2070
Tel: 1 (888) 422-7233
Website: www.iccsafe.org
- NAAMM National Association of Architectural Metal Manufacturers
800 Roosevelt Road
Building C, Suite 312
Glen Ellyn, IL 60137
Tel: (630) 942-6591
Website: www.naamm.org
- NFPA National Fire Protection Association
1 Batterymarch Park
P.O. Box 9101
Quincy, MA 02269
Tel: (617) 770-3000
Website: www.nfpa.org
- NVLAP National Voluntary Laboratory Accreditation Program
100 Bureau Drive
M/S 2140
Gaithersburg, MD 20899-2140
Tel: (301) 975-4016
Website: www.nvlap@nist.gov/nvlap
- UL Underwriters Laboratories, Inc.
333 Pfingsten Road
Northbrook, Illinois 60062
Tel: (847) 272-8800
Website: www.ul.com
- WHI Intertek Testing Services (Warnock Hersey) Inc.
3933 US Route 11
Courtland, New York 10345
Tel: (607) 758-6234
Website: www.intertek.com

APPENDIX 4

(Not part of the Standard)

OVER-VIEW OF ASTM SOUND CONTROL TESTS

To assist in understanding the terminology, testing and the appropriate selection of the types of ratings available, the following discussion is provided as strictly informational for the benefit of the reader. Copies of the Standards can be purchased from ASTM.

Frequency is a measure of how something 'sounds'. It is expressed in hertz (Hz). A low frequency is akin to a tuba and high a frequency that of a flute. The human ear is most sensitive to mid-range frequency sounds, then those at the low-end, and least at high-end of the spectrum.

Decibel (dB) is a measure of loudness. An *objectively* measured 1 dB change at two different frequencies is the same change in loudness for both. A 3 dB change represents a doubling or halving of loudness.

Combining frequency with loudness, to our *subjective* ear, means 40 dB at 1250 Hz will *sound* louder than 40 dB at 200 or 3000 Hz. To accommodate these human sensitivities, the ASTM Standards include factoring or "weighting", known as an "equal loudness contours" to balance the results to our hearing. E413 STC value calculations ignore E90 STL values below 125 Hz, above 4000 Hz and de-emphasize those from 125 to 500 Hz.

In the determination of STC and OITC ratings, a Sound Transmission Loss (STL) data plot from an E90 test is compared to standardized graph shapes called the STC Contours. When an STL value is lower than its corresponding STC Contour value, it is called a 'deficiency' at that frequency.

For normal human speech and hearing the following is provided;

Typical E413 STC Rating Applications

- 25 - Normal speech understood clearly
- 30 - Normal speech muffled
- 35 - Loud speech heard, not understood clearly
- 40 - Loud speech heard, not understood
- 45 - Loud speech not heard
- 50 - Very loud speech heard, not understood
- 60 - Very loud speech not heard

Affect of STC Rating Changes

- 1 STC point - almost imperceptible
- 3 STC points - just perceptible
- 5 STC points - noticeable
- 10 STC points - twice or half as loud

Typical Decibel (dB) Levels

- 0 dB - near total silence
- 15 dB - whisper, watch ticking
- 60 dB - normal conversation
- 90 dB - lawnmower, train whistle
- 110 dB - car horn, power saw, train
- 120 dB - rock concert, diesel engine
- 125 dB - pneumatic riveter
- 140 dB - gunshot
- 180 dB - jet engine afterburner
- 200 dB - Saturn rocket

Affect of Decibel (dB) Increases

- 3 dB - 2 times louder
- 10 dB - 10 times louder
- 20 dB - 100 times louder
- 30 dB - 1,000 times louder
- 40 dB - 10,000 times louder
- 50 dB - 100,000 times louder
- 60 dB - 1,000,000 times louder

ASTM E90, Standard Test Method for Laboratory Measurement of Airborne Sound Transmission Loss of Building Partitions and Elements

This Standard describes the test method, equipment, calibrations, tolerances, etc. for the laboratory measurement of Sound Transmission Loss (STL) through walls or elements such as sound control door assemblies. It utilizes two separate chambers with calibrated acoustic and environmental control and measurement equipment. The chambers are acoustically isolated to eliminate outside influences. The test sample is mounted in the wall between the two chambers thus the only significant path for sound transmission is through the test specimen. Sound control door assemblies are normally tested in their operable condition, but may also be fully sealed to determine the performance of the door panel construction for comparative purposes.

The test frequencies (1/3 octave bands from 80 to 5000 Hz) and decibel levels are closely controlled and recorded for the 19 specified frequencies with the sound emanating first from one chamber and then the other. The two values at each frequency are averaged to establish the STL, in decibels (dB), for each frequency.

ASTM E413, Classification for Rating Sound Insulation

This Standard provides *one* method for translating STL data from an ASTM E90 test into a single number, referred to as the Sound Transmission Class (STC). This method is intended for products used in interior applications for speech, radio, television, and similar sources of noise. The STL values, from 16 frequencies at 1/3 octave bands (125 to 4000 Hz frequency, consistent with the frequency range of speech), are compared against the E413 STC Contour curve by plotting them together as a graph. The STC Contour location is adjusted in 1 dB increments on the "Y-axis" until the sum of all 'deficiencies' is not greater than 32 dB and the maximum 'deficiency' at any one frequency does not exceed 8 dB. The resulting intersection of the STC Contour at 500 Hz is the STC rating for the test specimen. The resulting STC number is therefore a weighted average based on individual STL values.

ASTM E1332, Standard Classification for Rating Outdoor-Indoor Sound Attenuation

This Standard provides a method for translating the STL data from an ASTM E90 test into a single number, called the Outdoor-Indoor Transmission Class (OITC). This methodology is intended primarily for exterior elements such as walls and openings in them for transportation noises such as vehicles and aircraft. It is also appropriate in specialized interior applications for machinery and industrial process noises. The major differences between E413 and E1332 are; the inclusion of the 80 Hz band, representing noise from a variety of low-frequency sources and; a separate STC Contour weighted accordingly. This means that the additional range must be incorporated into the testing performed under E90. The calculations are similar to E413 but generally produce a lower numeric value.

RECOMMENDED GUIDE SPECIFICATIONS FOR HOLLOW METAL DOORS AND FRAMES

HMMA 860 - Hollow Metal Doors and Frames

ANSI/NAAMM

HMMA 861 - Commercial Hollow Metal Doors and Frames

ANSI/NAAMM

HMMA 862 - Commercial Security Hollow Metal Doors and Frames

ANSI/NAAMM

HMMA 863 - Detention Security Hollow Metal Doors and Frames

ANSI/NAAMM

HMMA 865 - Sound Control Hollow Metal Door and Frame Assemblies

ANSI/NAAMM

HMMA 866 - Stainless Steel Hollow Metal Doors and Frames

ANSI/NAAMM

HMMA 867 - Commercial Laminated Core Hollow Metal Doors and Frames

RELATED HMMA DOCUMENTS

HMMA 800 - Introduction to Hollow Metal

ANSI/NAAMM

HMMA 801 - Glossary of Terms for Hollow Metal Doors and Frames

HMMA 802 - Manufacturing of Hollow Metal Doors and Frames

HMMA 803 - Steel Tables

HMMA 810 - Hollow Metal Doors

HMMA 820 - Hollow Metal Frames

HMMA 830 - Hardware Selection for Hollow Metal Doors and Frames

HMMA 831 - Recommended Hardware Locations for Hollow Metal Doors and Frames

HMMA 840 - Installation and Storage of Hollow Metal Doors and Frames

ANSI/NAAMM

HMMA 841 - Tolerances and Clearances for Commercial Hollow Metal Doors and Frames

HMMA 850 - Fire-Rated Hollow Metal Doors and Frames

HMMA 890 - Technical Summary

HMMA 810-TN01 - Defining Undercuts

HMMA 820-TN01 - Grouting Hollow Metal Frames

HMMA 820-TN02 - Continuously Welded Frames

HMMA 820-TN03 - Guidelines for Glazing Hollow Metal Transoms, Sidelights and Windows

HMMA 840-TN01 - Painting Hollow Metal Products

HMMA 840-TN02 - Maintenance of Installed Hollow Metal Products