



PHARMACEUTICAL / FOOD

Next Door makes fully seamless doors and frames that meet or exceed the specifications of most hospital or pharmaceutical jobs. Next Door has manufactured doors and frames for virtually every major pharmaceutical manufacturer in the United States and done many jobs for medical research and clean-room applications.

Next Door goes to unmatched lengths to ensure performance and aesthetic appeal in every seamless door and frame:

- Door edges, tops and bottoms are fully and continuously TIG welded with stainless steel filament and hand polished for a fully seamless and water-tight condition.
- Pharmaceutical frames have a pencil-thin fillet weld on all seams. There are no exposed seams anywhere.
- All hardware/componentry is welded inside to eliminate any visible weld marks.
- All welds are acid washed before finishing to remove any discoloration and passivate the steel.
- Frame headers are regrained to match the grain of the door and side jamb.
- Hospital stops are completely welded, repolished and regrained to match the desired finish.
- We offer lite kits with no visible seams, as well as flush lite kits, etc., for easy maintenance.
- Cores are designed to reduce or eliminate the presence of harbored germs.

FOOD PROCESSING

- Special non-welded cores for aesthetics.
- Because of our construction, cores are unaffected by wash-down.

MEDICAL

LEAD-LINING AVAILABLE

- We will factory install lead in frames or doors.
- Lead can be included by Next Door or furnished by others.
- We can prepare frames to receive lead to be furnished and installed by others.



PHARMACEUTICAL / FOOD

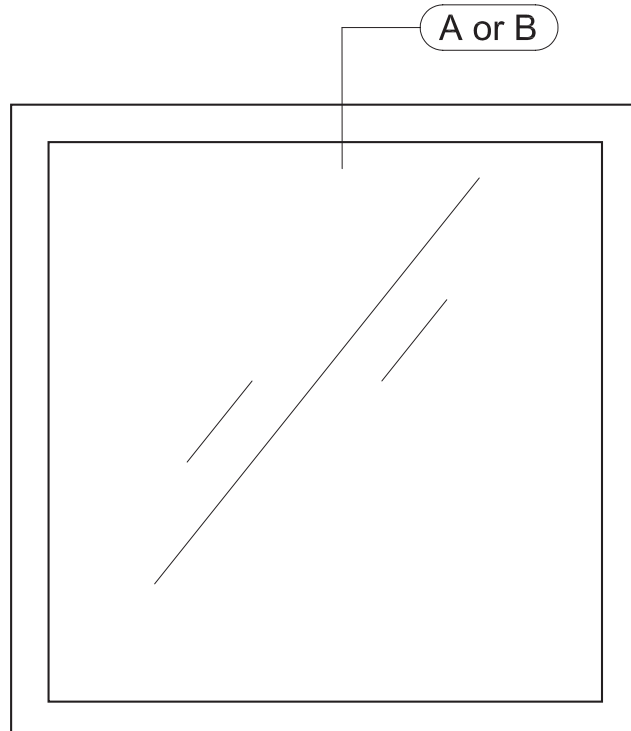

ELEVATION

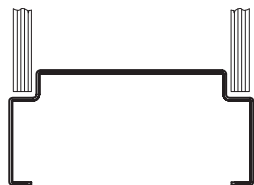

(A) OPTION 1
FLUSH GLASS SECTION

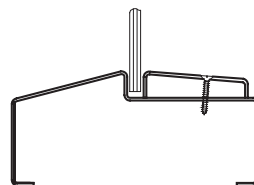

(B) OPTION 2
SLOPED SECTION



PHARMACEUTICAL / FOOD

CAPPED, WELDED DOOR CHANNEL

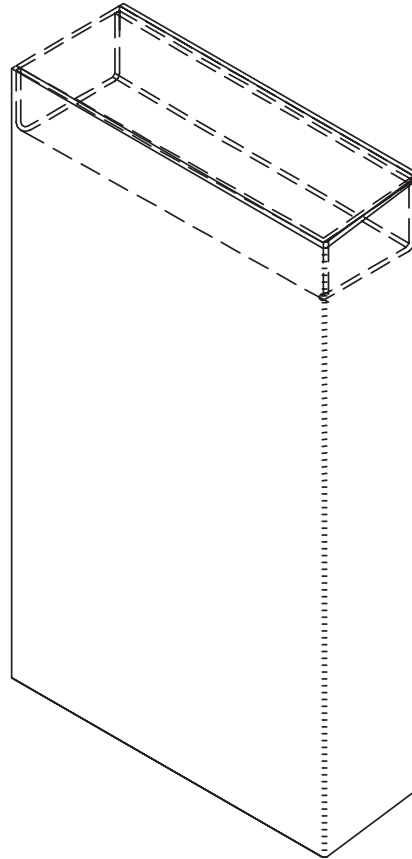

Fully-welded ground
smooth & finished flush

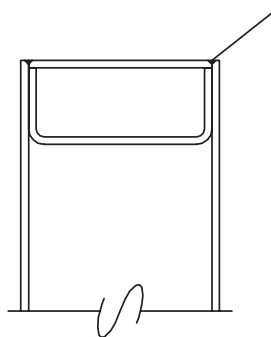

TOP & BOTTOM
(STANDARD METHOD)



PHARMACEUTICAL / FOOD

FULLY-WELDED CORNER CONSTRUCTION

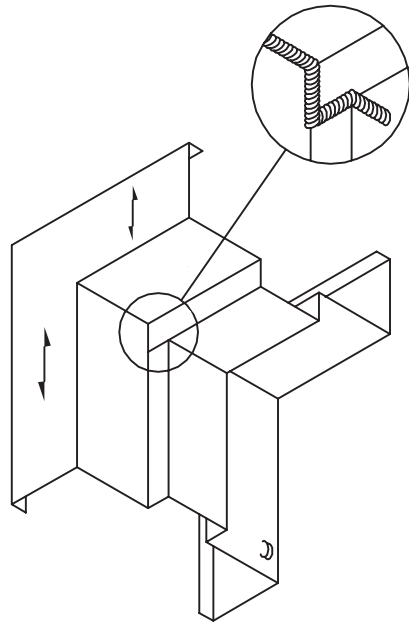

Continuously weld face, full width and depth, and acid wash clean

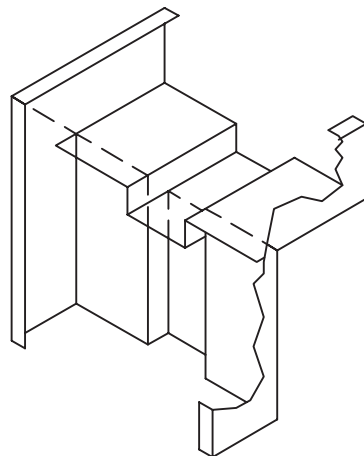
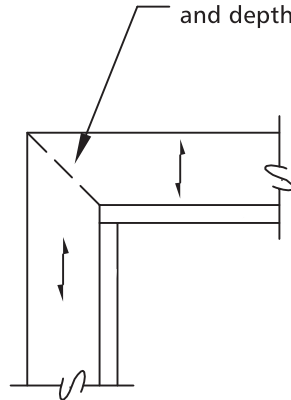



PHARMACEUTICAL / FOOD HOSPITAL STOPS

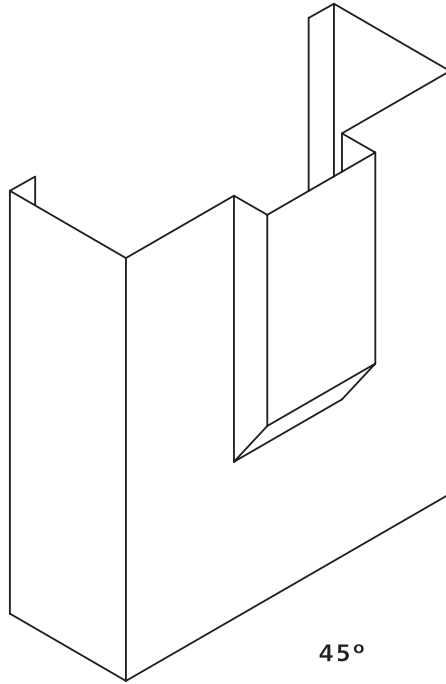

45°

NOTE: Stops are fully and continuously welded, ground smooth, refinished and repolished to a #4 finish.

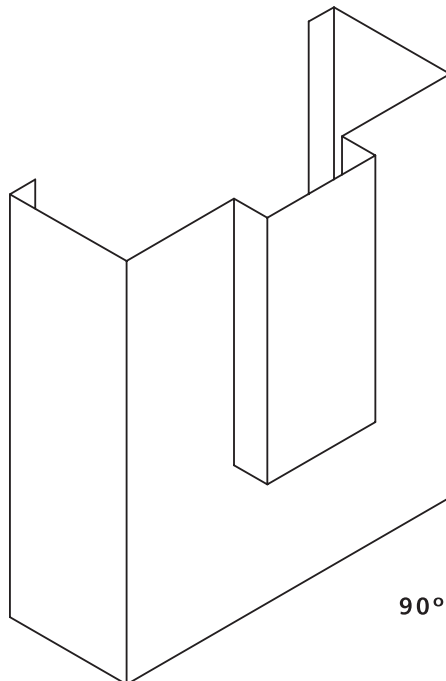

90°