

**HOLLOW
METAL
MANUAL** | AMERICAN NATIONAL STANDARD
ANSI/
NAAMM

HMMA 861 -14
08 11 13 Hollow Metal Doors and Frames

GUIDE SPECIFICATIONS FOR COMMERCIAL HOLLOW METAL DOORS AND FRAMES

SEVENTH EDITION
September 15, 2014



This standard was developed by representative members of and approved by the Hollow Metal Manufacturers Association Division (HMMA) of the National Association of Architectural Metal Manufacturers (NAAMM) to provide their opinion and guidance on the specification and use of swinging sound control hollow metal doors and frames. This standard contains advisory information only and is published as a public service by NAAMM and its HMMA Division.

NAAMM AND ITS HMMA DIVISION DISCLAIM ALL LIABILITY OF ANY KIND FOR THE USE, APPLICATION OR ADAPTATION OF MATERIAL PUBLISHED IN THIS STANDARD.

Current information on all NAAMM Standards is available by calling, writing, or visiting the website of the National Association of Architectural Metal Manufacturers, www.naamm.org.

National Association of Architectural Metal Manufacturers
800 Roosevelt Road, Building C, Suite 312
Glen Ellyn, IL 60137
Tel: 1-630-942-6591 · Fax: 1-630-790-3095
www.naamm.org

*Copyright © 1974, 1976, 1987, 1993, 2000, 2006, 2014
All Rights Reserved*

FOREWORD

These specifications have been prepared in accordance with the CSI recommended Master Format 2012 with Part 1 - General, Part 2 - Product and Part 3 - Execution. Guide specifications are intended to be used as the basis for developing project specifications and must be edited to fit specific project requirements. Inapplicable provisions should be deleted, appropriate selections should be made where there are choices, and provisions applicable to the project should be added where necessary. Options are shown in brackets. Notes, recommendations and instructions to Specifiers are given in italics at the start of or directly following the sections to which they apply. Notes that contain permissive language are not considered part of the standard. ASTM and other standards shall be deemed as that in affect on publication date of this Guide, unless specifically noted otherwise. When a more recent standard is available, the Specifier should verify its applicability to this Guide prior to its inclusion. While the CSI Section Format locates Delivery, Storage and Handling in Part 1, NAAMM standards include them under Part 3 – Execution.

Materials and fabrication methods are specified in detail in Part 2. Doors and frames manufactured in accordance with these specifications have successfully met the testing and performance requirements of Section 1.05. However, the materials and fabrication methods called for in these specifications, while providing an excellent guide, are not intended to restrict the use of other materials and methods where it can be demonstrated through the specific testing procedures in Section 1.05 that the construction can equal or exceed the performance levels specified. In order to ensure that a manufacturer's product meets the desired performance levels, the construction specifications must always include the Testing and Performance requirements of Section 1.05 and the Quality Assurance requirements of Section 1.06.

The values stated in inch-pound units are to be regarded as the standard. Corresponding metric values are included in parenthesis for reference purposes only.

This guide specification addresses the requirements for commercial steel stiffened hollow metal doors and frame products.

For hollow metal doors and frames subject to less rigorous use than commercial and institutional applications, give consideration to ANSI/NAAMM HMMA 860, "Guide Specifications for Hollow Metal Doors and Frames", or ANSI/NAAMM HMMA 867, "Guide Specifications for Commercial Laminated Core Hollow Metal Doors and Frames". If security is a factor, there are two hollow metal standards available - ANSI/NAAMM HMMA 862, "Guide Specifications for Commercial Security Hollow Metal Doors and Frames", and ANSI/NAAMM HMMA 863, "Guide Specifications for Detention Security Hollow Metal Doors and Frames". For acoustic applications consideration may be given to ANSI/NAAMM HMMA 865, "Guide Specifications for Sound Control Hollow Metal Doors and Frame Assemblies". For situations where corrosion resistance beyond that of typical commercial steel door and frame applications, or where specialized aesthetic appearance, are significant design criteria, consideration should be given to ANSI/NAAMM HMMA 866, "Guide Specifications for Stainless Steel Hollow Metal Doors and Frames".

CSI SECTION 08 11 13 HOLLOW METAL DOORS AND FRAMES

PART 1 - GENERAL

1.01 SUMMARY

This Section includes commercial hollow metal products, including doors, panels, frames, transom frames, sidelight and window assemblies as shown in the contract documents.

1.02 PRODUCTS PROVIDED UNDER THIS SECTION

- A. Commercial hollow metal doors, swinging type, including [glass moldings and stops] [louvers] [louwer inserts] [other] as shown in the approved submittal drawings.
- B. Commercial hollow metal panels, fixed or removable, flush or rabbeted, similar in construction to hollow metal doors.
- C. Commercial hollow metal frames, transom frames, sidelight and window assemblies, including [glass moldings and stops] [louvers] [louwer inserts] [hollow metal panels] [in-fill panels] [other] as shown in the approved submittal drawings.

In this guide specification the term "frame product" is used to define, as, a group; frames, transom frames, sidelights, and window assemblies.

1.03 RELATED SECTIONS

- A. Section 01 66 00 - Product Storage and Handling
- B. Section 03 30 00 – Cast in Place Concrete
- C. Section 04 20 00 – Unit Masonry
- D. Section 05 10 00 - Structural Metal Framing (for Lintels, Posts, Columns or Other Load Bearing Elements)
- E. Section 06 11 00 - Wood Framing
- F. Section 08 11 19 - Stainless Steel Doors and Frames
- G. Section 08 34 53 - Security Doors and Frames
- H. Section 08 34 73 - Sound Control Doors and Frames
- I. Section 08 71 00 - Door Hardware (including Weather Stripping and Seals)
- J. Section 08 80 00 - Glazing
- K. Section 09 20 00 – Plaster and Gypsum Board (for the Installation of Commercial Hollow Metal Doors and Frames in Steel Stud Partitions).
- L. Section 09 90 00 - Painting and Coating
- M. Section 11 19 00 - Detention Equipment
- N. Section ___ ___ ___ - Field Measurements

This specification covers only those products listed in Section 1.02. Not included in Section 08 11 13 are builders or rough hardware of any kind, weather-stripping, gasketing, items furnished by others, field painting, and protection at the building site of products furnished under this Section.

1.04 REFERENCES

The Standards listed in this Guide are referenced by basic designation only. The edition of a Standard is deemed as that in affect on the publication date this Guide, unless specifically noted otherwise. If a more recent standard is available, the Specifier should verify its applicability to this Guide prior to its inclusion.

- A. ANSI/SDI A250.4, Test Procedure and Acceptance Criteria for Physical Endurance for Steel Doors, Frames and Hardware Reinforcings
- B. ANSI/SDI A250.10, Standard Test Procedure and Acceptance Criteria for Prime Painted Steel Surfaces for Steel Doors and Frames
- C. ANSI/NAAMM HMMA 801, Glossary of Terms for Hollow Metal Doors and Frames
- D. ANSI/NAAMM HMMA 841, Tolerances and Clearances for Commercial Hollow Metal Doors and Frames
- E. ANSI/NAAMM HMMA 866, Guide Specifications for Stainless Steel Hollow Metal Doors and Frames
- F. ANSI/NFPA 80 , Standard for Fire Doors and Other Opening Protectives
- G. ANSI/NFPA 105, Standard for the Installation of Smoke Door Assemblies and Other Opening Protectives.
- H. ANSI/NFPA 252, Standard Methods of Fire Tests of Door Assemblies
- I. ANSI/NFPA 257, Standard Fire Test for Windows and Glass Block Assemblies
- J. ANSI/UL 9, Fire Test of Window Assemblies
- K. ANSI/UL 10C, Positive Pressure Fire Tests of Door Assemblies
- L. ANSI/UL 1784, Air Leakage Test of Door Assemblies
- M. ASTM A 653/A 653M, Specification for Steel Sheet, Zinc Coated (Galvanized) or Zinc-Iron Alloy-Coated (Galvannealed) by the Hot-Dip Process
- N. ASTM A 1008/A 1008M, Specification for Steel, Sheet, Cold-Rolled, Carbon, Structural, High Strength Low-Alloy and High Strength Low-Alloy with Improved Formability, Solution Hardened, and Bake Hardenable
- O. ASTM A 1011/A 1011M, Specification for Steel, Sheet, and Strip, Hot-Rolled, Carbon, Structural, High Strength Low-Alloy and High Strength Low-Alloy with Improved Formability and Ultra High Strength
- P. ASTM C 143/A 143M, Test Method for Slump of Hydraulic-Cement Concrete
- Q. CAN/ULC-S104, Standard Method for Fire Test of Door Assemblies
- R. CAN4-S106, Standard Method for Fire Test of Window and Glass Block Assemblies
- S. NAAMM HMMA 802, Manufacturing of Hollow Metal Doors and Frames
- T. NAAMM HMMA 803, Steel Tables
- U. NAAMM HMMA 805, Recommended Selection and Usage Guide
- V. NAAMM HMMA 810, Hollow Metal Doors
- W. NAAMM HMMA 810 TN01, Defining Undercuts of Doors
- X. NAAMM HMMA 820, Hollow Metal Frames
- Y. NAAMM HMMA 820 TN01, Grouting Hollow Metal Frames
- Z. NAAMM HMMA 820 TN02, Continuously Welded Frames
- AA. NAAMM HMMA 830, Hardware Selection for Hollow Metal Doors and Frames
- AB. NAAMM HMMA 831, Recommended Hardware Locations for Hollow Metal Doors and Frames
- AC. NAAMM HMMA 840, Guide Specifications for Installation and Storage of Hollow Metal Doors and Frames
- AD. NAAMM HMMA 840 TN01, Painting Hollow Metal Products

AE. NAAMM HMMA 850, Fire-Rated and Smoke Control Hollow Metal Door and Frame Products

The following standards are used only for neutral pressure fire test methods and should be deleted from project specifications when 'positive pressure' is required by the governing building code: CAN/ULC-S104 (1.04.R) and CAN4-S106 (1.04.S)

Conversely, ANSI/UL 10C (1.04.L) is used only for positive pressure fire tests and should be deleted from project specifications requiring neutral pressure fire tests.

ANSI/NFPA 252 (1.04.H), ANSI/NFPA 257 (1.04.I) and ANSI/UL 9 (1.04.J) reference both neutral pressure and 'positive pressure' fire test methods, and as such should be included in all project specifications, except those requiring compliance with Canadian Building Codes.

ANSI/UL 1784 (1.04.M) is used for US smoke control assembly testing and therefore should not be included in specifications requiring compliance with the Canadian Building Code.

Only project specifications requiring compliance with Canadian Building Codes should include CAN/ULC-S104 (1.04.R) and CAN4-S106 (1.04.S)

Refer to Appendix 4 for a list of the Standards Writing or Accreditation Organizations referenced in Section 1.04.

1.05 TESTING AND PERFORMANCE

A. Physical Endurance for Steel Doors and Hardware Reinforcings

1. Test a 3 ft. x 7 ft. (914 mm x 2134 mm), 1.75 in. (44 mm) thick nominal size door representative of the construction and material to be provided.
2. Test in accordance with ANSI/SDI A250.4, Cycle and Twist Test procedure.
 - a. Cycle Test Acceptance Criteria:
 - i. Doors specified with 0.053 in. (1.3 mm) and thicker face sheets tested to 4,000,000 cycles.
 - ii. Doors specified with 0.042 in. (1.0 mm) minimum thick face sheets tested to Level A (1,000,000 cycles).
 - b. Twist Test Acceptance Criteria: Maximum deflection under 300 pound (136.1 kg) load.
 - i. 4,000,000 cycle-tested doors not to exceed 0.625 in. (15.8 mm) deflection and maximum permanent deflection not to exceed 0.062 in. (1.5 mm).
 - ii. 1,000,000 cycle-tested doors not to exceed 1.25 in. (31.7 mm) deflection and maximum permanent deflection not to exceed 0.125 in. (3.1 mm).
3. Provide Verification of Compliance from an Independent 3rd party which include a description of the test specimen, procedures used in testing, and indicate compliance with the acceptance criteria of the standard.

B. Labeled Fire-Rated and/or Smoke Control Door and Frame Product

1. Where determined and scheduled by the Architect;
 - a. Provide Listed or Classified doors, panels, frames, transom frames, sidelight, borrowed light and window assemblies bearing the label of a testing agency having a factory inspection service for openings requiring fire protection and/or smoke control ratings.
 - b. Test doors, panels, frames, transom frames and sidelight assemblies in accordance with [ANSI/NFPA 252] [CAN/ULC-S104] [ANSI/UL 10C] [and/or] [ANSI/UL 1784].
 - c. Test borrowed light and window assemblies in accordance with [ANSI/UL9 or ANSI/NFPA 257] [CAN4-S106].

ANSI/UL 10C provides for positive pressure testing to accommodate the requirements of IBC jurisdictions and should be included only for such.

CAN/ULC-S104 and CAN4-S106 provide for 'neutral pressure' testing to accommodate the requirements of the Canadian Building Code jurisdictions and should be included only for such.

ANSI/NFPA 252, ANSI/NFPA 257 and ANSI/UL 9 cover both neutral and positive pressure testing and therefore should be included in all project specifications, except when compliance with Canadian Building Codes is required.

ANSI/UL 1784 provides for smoke control assembly testing required by the IBC and ANSI/NFPA 105 to accommodate these specific requirements and should be included only when required.

Include CAN/ULC-S104 and CAN4-S106 only for projects requiring conformance with Canadian Building Codes.

2. For any door or frame product specified by the Architect to be fire-rated, which cannot qualify for labeling due to design, hardware or other reason, advise the Architect, in the submittal documents. Advise the Architect when hardware, glazing or other options specified, unknown at the time of submittal document preparation, affect fire labeling eligibility.

The Specifier must ensure that all performance based criteria such as fire-protection rating, temperature-rise rating, smoke control for each opening are clearly detailed by the Architect on the project door schedules.

For additional information, refer to NAAMM HMMA 850, "Fire-Rated and Smoke Control Hollow Metal Door and Frame Products".

C. Prime Paint Performance

1. Sheet steel specimens, with the product manufacturer's production primer, replicating finish 'as shipped', tested in accordance with ANSI/SDI A250.10
2. Provide Verification of Compliance from an Independent 3rd party which include a description of the test specimen, procedures used in testing, and indicate compliance with the acceptance criteria of the standard.

1.06 QUALITY ASSURANCE

A. Manufacturer's Qualifications

1. Provide evidence of having personnel and plant equipment capable of fabricating hollow metal door and frame product of the types specified.
2. Provide evidence of having a written quality control system in place.

B. Quality Criteria

1. Compliance with Section 1.05 is required for all door and frame product provided under this Section.
2. Fabricate in accordance with the approved submittal drawings.
3. Meet fabrication methods and product quality standards set by the Hollow Metal Manufacturers Association, HMMA, a division of the National Association of Architectural Metal Manufacturers, NAAMM, as set forth in the contract documents and NAAMM's HMMA 800 through 850 Series documents.

1.07 SUBMITTALS

A. Submittal Drawings

1. Show dimensioned door and frame product elevations and sections.
2. Show listing of opening descriptions including locations, material thicknesses, and anchors.
3. Show location and details of openings.
4. Provide manufacturer's recommended installation instructions and procedures.

B. Samples, upon request, provide the following.

1. Door: 1 ft. x 1 ft. (305 mm x 305 mm) corner section with hinge preparation showing top and internal construction.

2. Frame: 1 ft. x 1 ft. (305 mm x 305 mm) section showing assembled corner joint at head and jamb. Include hinge reinforcement [and grout guard] in one rabbet. When glazed frame product is specified, apply and install glazing stop as specified in the opposite rabbet. Apply glazing stop to both head and jamb section to show their intersection.
 3. All samples submitted must represent in all respects the minimum quality of work to be furnished by the manufacturer. Do not fabricate any work represented by the samples until the samples are approved. Any deviation of fabrication quality compared to the approved samples is cause for rejection of the work.
- C. Contractor responsible for coordination and installation of products covered under this Section will;
1. Verify and provide to the manufacturer, actual opening sizes and site conditions by field measurements before fabrication. Coordinate field measurements with fabrication and construction schedules to avoid delays.
 2. Verify that substrate conditions, whether existing or installed under other Sections, are as detailed in the Architect's drawings, and are acceptable for product installation in accordance with the manufacturer's instructions.
- D. Reflect measurements and conditions determined under Section 1.07.C in submittal documents and manufacture product accordingly.
- E. Do not proceed with fabrication without receipt of approved submittal drawings and approved hardware schedules.
- The approved submittal drawings and the approved hardware schedule are the versions that have been provided to the hollow metal manufacturer at the time of release for fabrication. These drawings and the schedule are considered part of the project construction documents. Insist upon receiving detailed templates along with approved submittal drawings to assure proper coordination between Contractor and installers.*
- F. Contractor responsible for the coordination of procuring products provided under this Section and Section 1.03 - Related Sections is hereby instructed to comply with the hollow metal manufacturer's ordering instructions and lead time requirements to avoid delays.

PART 2 - PRODUCTS

2.01 HOLLOW METAL DOORS

A. Materials

1. Steel

- a. Cold-rolled steel conforming to ASTM A 1008/A 1008M, CS, Type B
- b. Hot-rolled, pickled and oiled (HRPO) steel conforming to ASTM A 1011/A 1011M, CS, Type B
- c. Zinc-coated steel conforming to ASTM A 653/A 653M, CS, Type B

B. Construction

ANSI and ASTM Standards no longer utilize 'gage' to define steel thickness. In this Specification steel is expressed in terms of minimum decimal inch (millimeter) thickness. Dimensions or sizes traditionally expressed in fractional inches are shown in decimal inches (millimeters). HMMA has developed a series of Tables, (NAAMM HMMA 803) included as Appendix 1 of this Specification, to summarize the imperial standards and their corresponding metric values.

1. Fabricate types, sizes, and construction, in accordance with the contract documents, and meeting the performance requirements of Section 1.05.
2. Door face sheet thickness and steel type.
 - a. Interior doors constructed of 0.042 in. (1.06 mm) minimum thickness commercial quality steel sheet, free of scale, pitting or surface defects, conforming to; ASTM A 1008/A 1008M for cold-rolled steel; ASTM A 653/A 653M, CS, Type B, Coating Designation A25 (ZF75) for zinc-coated steel; or ASTM A 1011/A 1011M, CS, Type B, for hot-rolled pickled and oiled steel.

For interior doors subject to corrosive conditions it is recommended that zinc-coated face sheets, as specified in 2.01.B.2.b, be used.

- b. Exterior doors constructed of 0.053 in. (1.3 mm) minimum thickness zinc-coated steel conforming to ASTM A 653/A653M, CS, Type B, Coating Designation A60 (ZF180) or G60 (Z180).

If the Architect determines that zinc coated face sheets and internal components are needed, 2.01.B is the appropriate location to specify this requirement.

For doors subject to severely corrosive conditions it is recommended that stainless steel products, as detailed in NAAMM's ANSI/NAAMM HMMA 866, "Guide Specifications for Stainless Steel Hollow Metal Doors and Frames", be utilized.

3. Join face sheets at their vertical edges by a continuous weld extending the full height of the door, with no visible seams on their faces or vertical edges.

See "Welded, Continuously" in ANSI/NAAMM HMMA 801, "Glossary of Terms for Hollow Metal Doors and Frames"

4. Fabricate doors with minimum nominal door thickness of 1.75 in. (44 mm). Fabricate doors neat in appearance and free from warpage or buckle. Bend edges true and straight, and of minimum radius for the thickness of metal used.
5. Prior to shipment mark each door with an identification number as shown on the approved submittal drawings.
6. Stiffen doors using continuous vertically formed steel sections which, upon assembly, span the full thickness of the interior space between door faces. Fabricate stiffeners from 0.026 in. (0.6 mm) minimum thickness steel and space them so that the vertical interior webs are no more than 6 in. (152 mm) apart. Securely fasten stiffeners to both face sheets by spot welds spaced a maximum of 5 in. (127 mm) on center vertically. Fill spaces between stiffeners with fiberglass or mineral rock wool batt-type material.
 - a. Where determined and scheduled by the Architect, insulate temperature rise rated (TRR) fire doors to limit the temperature rise on the "unexposed" side of the door, as required by the governing building code requirements.
7. Close the top and bottom edges with a continuous steel channel, not less than 0.053 in. (1.3 mm) thickness, welded to both face sheets.
8. Close exterior doors, or doors where otherwise scheduled by the Architect, flush at the top edge. Where required for attachment for weather-stripping, provide a flush steel closure channel at the bottom edge. Provide openings in the bottom closure channel of exterior doors to permit the escape of entrapped moisture.
9. Provide edge profiles on both vertical edges of doors as follows, unless hardware dictates otherwise:
 - a. Single acting doors - beveled .125 in. (3.1 mm) in 2 in. (50.8 mm) profile
 - b. Double acting doors - rounded on 2.125 in. (54 mm) radius
10. Hardware Reinforcements and Preparations
 - a. Weld all hardware reinforcements to door.
 - b. Mortise, reinforce, drill and tap doors at the factory for templated hardware only, in accordance with the approved hardware schedule and templates provided by the hardware supplier.
 - c. Mortise and reinforce doors for anchor hinges, thrust pivots, pivot reinforced hinges, or non-templated hardware. Drilling and tapping, by others.
 - d. Reinforce doors for surface mounted hardware or continuous hinges. Drilling and tapping, by others

- e. Steel thickness for hardware reinforcements to be the manufacturer's standard as required to adequately support the door and hardware, but not less than:
 - i. Full mortise hinges and pivots.....0.167 in. (4.24 mm) or 0.123 in. (3.12 mm) angle or channel shaped type
 - ii. Lock fronts, mortised latching devices and strikes.....0.093 in. (2.3 mm) or 0.053 in. (1.34 mm) unitized reinforcement with extruded tapped holes that provide equivalent number of thread as 0.093 in. (2.3 mm)
 - iii. Concealed holders and surface mounted closers.....0.093 in. (2.3 mm)
 - iv. Internal reinforcements for other surface mounted hardware.....0.067 in. (1.7 mm)
- f. Where power operated hardware is indicated on the approved hardware schedule, provide access from hinge edge to device in accordance with the templates provided.

11. Glazing Moldings and Stops

- a. Where specified or scheduled, provide doors with steel moldings to secure glazing materials furnished and installed in the field by others, in accordance with glazing sizes and thickness shown in the contract documents.
- b. Provide fixed glazing molding or integral stops, 0.032 in. (0.81 mm) minimum thickness, located on the secure side of the door, as designated on the Architect's drawings and/or door schedules.
- c. Fabricate channel shaped removable glazing stops not less than 0.032 in. (0.8 mm) material thickness, with tight fitting butt or mitered corners, and secure with #6 minimum, corrosion resistant countersunk sheet metal screws.
- d. Treat metal surfaces to which removable glazing stops are applied and the inside of the removable glazing stops for maximum paint adhesion and coat with a rust inhibitive primer prior to installation in the door. Glazing stops fabricated from zinc-coated steel conforming to ASTM A 653/A 653M, A25 (ZF75) for interior doors, A60 (ZF180) for exterior openings need not be primed on the inside.
- e. Prepare fire-protection rated doors for listed glazing as required in accordance with the door manufacturer's fire rating procedure.

12. Louvers.

- a. Provide doors with louvers where specified in the contract documents.
- b. Louvers for non-fire-protection rated doors; welded inverted V type, Y type or Z type, face sheet pierced construction or louver inserts.
- c. Fabricate welded inverted V, Y and Z type vanes from 0.042 in. (1.06 mm) minimum thickness steel, matching the Type and Finish of the door face sheets.
- d. Prepare fire-rated doors for listed, fire door louvers.
- e. Provide insect and/or bird screens at louvers for exterior application doors where shown on the contract documents.

2.02 HOLLOW METAL PANELS

- A. Hollow metal panels, 1.75 in. (44 mm) nominal thickness, of the same materials and construction as specified in Section 2.01 of this specification.
- B. Finish hollow metal panels as specified in Section 2.06 of this specification.

2.03 HOLLOW METAL FRAMES

Provisions of Section 2.03 are applicable to frames, transom frames, sidelight and window assemblies, unless indicated otherwise.

A. Materials

1. Steel

- a. Cold-rolled steel conforming to ASTM A 1008/A 1008M, CS, Type B
- b. Hot-rolled, pickled and oiled (HRPO) steel conforming to ASTM A 1011/A 1011M, CS, Type B
- c. Zinc-coated steel conforming to ASTM A 653/A 653M, CS, Type B

B. Construction

1. Fabricate frame product as welded units of the sizes and types shown on the approved submittal drawings. Frame product shall be constructed in accordance with the contract documents and meet the performance criteria specified in Section 1.05. Knocked-down frames are not acceptable.
2. Profile thickness and steel type:

- a. Interior Frame Product: Construct profiles of commercial quality steel sheet, free of scale, pitting or surface defects; cold-rolled steel conforming to ASTM A 1008/A 1008M; zinc-coated steel conforming to ASTM A 653/A 653M, CS, Type B, Coating Designation A25 (ZF75); or hot-rolled, pickled and oiled steel conforming to ASTM A 1011/A 1011M, 0.053 in. (1.3 mm) minimum thickness. Fabricate frame product from 0.067 in. (1.7 mm) minimum thickness for single door openings exceeding 4 ft. (1219 mm) in width, pairs with either door exceeding 4 ft. (1219 mm) in width and for nominal door opening height exceeding 10 ft. (3048 mm).

For interior areas subject to corrosive conditions it is recommended that zinc-coated frame product, as specified in 2.03.B.2.b, be used.

- b. Exterior Frame Product: Construct profiles from zinc coated steel conforming to ASTM A 653/A 653M, CS, Type B, Coating Designation A60 (ZF180) or G60 (Z180), 0.053 in. (1.3 mm) minimum thickness. Fabricate frame product from 0.067 in. (1.7 mm) minimum thickness for single door openings exceeding 4 ft. (1219 mm) in width, pairs with either door exceeding 4 ft. (1219 mm) in width and for nominal door opening height exceeding 10 ft. (3048 mm).

If the Architect determines that zinc coated frame product and internal components are needed, 2.03.B is the appropriate location to specify this requirement.

For frame product subject to severely corrosive conditions it is recommended that stainless steel products, as detailed in NAAMM's ANSI/NAAMM HMMA 866, "Guide Specification for Stainless Steel Hollow Metal Doors and Frames", be utilized.

3. Fabricate all finished work neat in appearance, square, and free of defects, warps and buckles. Pressed steel members shall be straight and of uniform profile throughout their lengths.
4. Provide jamb, header, mullion and sill profiles in accordance with the frame schedule and as shown on the approved submittal drawings.
5. Fabricate corner joints with all contact edges closed tight, with faces mitered where the two joining members faces are equal, and with stops mitered or butted.
6. Welding
 - a. Perimeter face joints (flush or indented): Continuously welded internally or externally with flush face joints finished smooth with seamless faces. Continuously weld internally the rabbets and soffits.
 - b. Internal flush face joints: Continuously welded and finished smooth with seamless faces.
 - c. Members at internal indented intersections: Securely welded to concealed reinforcements, and have hairline face seams.

- d. All other intersection elements: Hairline seams.

See NAAMM HMMA 820, "Hollow Metal Frames", and NAAMM HMMA 820-TN02-03, "Continuously Welded", and Figure 1 of this specification, for further details on frame welding.

- 7. Fabricate frame product with stop heights of 0.625 in. (15.8 mm) minimum.
- 8. Cap cut-off stops, where specified, at heights as shown on the approved submittal drawings, weld, fill and grind smooth so that there are no visible seams at the jamb joints below cut-off stops.

It is recommended that cut off stops not be used at exterior, lead lined, double egress or gasketed openings.

- 9. Prepare each door opening for single stud, resilient door silencers, three (3) per strike jamb for single door openings, two (2) per head for pairs, except on gasketed or weather stripped frame product. Silencers supplied and installed by others.
- 10. When shipping limitations or site access so dictate, or when advised by the contractor responsible for coordination or installation, fabricate frame product for large openings in sections designated for assembly in the field. Install alignment plates or angles at each joint of the same material and thickness as the frame in accordance with approved submittal drawings.. Assemble sections, weld joints, grind smooth and prime paint by others under Section 06 11 00 or 09 20 00.
- 11. Prior to shipment mark frame product with an identification number as shown on the approved submittal drawings.

12. Hardware Reinforcements and Preparations

- a. Weld all hardware reinforcements to frame product.
- b. Mortise, reinforce, drill and tap frame product at the factory for templated hardware only, in accordance with the approved hardware schedule and templates provided by the hardware supplier.
- c. Mortise and reinforce frame product for anchor hinges, thrust pivots or non-templated mortised hardware. Drilling and tapping, by others.
- d. Reinforce frame product for surface mounted hardware or continuous hinges. Drilling and tapping, by others.

See NAAMM HMMA 830, "Hardware Selection for Hollow Metal Doors and Frames" for additional information.

- e. Minimum thickness of hardware reinforcements;
 - i. Full mortised hinges and pivots.....0.167 in. x 1.25 in. x 10 in. length
(4.2 mm x 31.7 mm x 254 mm)
 - ii. Strikes.....0.093 in. (2.3 mm) or 0.053 in.
(1.3 mm) unitized reinforcement
with extruded tapped holes that
provide equivalent number of
threads as 0.093 in. (2.3 mm)
 - iii. Flush bolts, closers, hold open arms, and other
surface applied hardware.....0.093 in. (2.3 mm)

- 13. Where power operated hardware is indicated on the Architect's drawings or approved hardware schedule, provide prepared grout guards in accordance with the templates provided. Fabricate access plates, where required, of the same material, thickness and finish as the frame product, fastened with corrosion resistant screws. Secure access plates with a minimum of four (4) #8-32 machine screws or #6 sheet metal screws, spaced at 12 in. (305 mm) on center maximum.

14. Floor Anchors

- a. Weld floor anchors inside jambs. Provide two (2) holes for fasteners supplied and installed by others under Section [06 10 00] [09 20 00].

- b. Where specified or scheduled, provide adjustable floor anchors with no more than 2 in. (50.8 mm) height adjustment.
- c. For applications that do not permit the use of a floor anchor, substitute an additional jamb anchor at a location not to exceed 8 in. (204 mm) from the base of the jamb.
- d. Thickness of floor anchor; same as frame, minimum..

15. Jamb Anchors

- a. Provide frame product with anchorage appropriate to frame and wall construction.
- b. Masonry Type:

Provide steel adjustable jamb anchors of the strap and stirrup or T-strap type not less than 0.053 in. (1.34 mm) thickness or 0.156 in. (4 mm) diameter wire type, for frame product to be installed in new masonry walls. Straps; 2 in. x 10 in. (50 mm x 254 mm) in size minimum, corrugated and/or perforated. Place jamb anchors at a maximum of 18 in. (457 mm) from top and bottom of openings. Minimum number of anchors, spaced at maximum of 32 in. (813 mm) on center, provided on each jamb based on the over-all frame height.

- i. Up to 60 in. (1524 mm).....2 anchors
- ii. Greater than 60 in. (1524 mm)
up to 90 in. (2286 mm).....3 anchors
- iii. Greater than 90 in. (2286 mm)
up to 96 in. (2438 mm).....4 anchors
- iv. Greater than 96 in. (2438 mm).....4 anchors plus one for each 24 in.
(610 mm) or fraction thereof, spaced
at 24 in. (610 mm) maximum between
anchors

- c. Dry Wall Type

Provide steel jamb anchors of suitable design, not less than 0.042 in. (1.06 mm) thickness, welded inside each jamb for frame product installed in drywall partitions. Place jamb anchors at a maximum of 18 in. (457 mm) from top and bottom of openings. Minimum number of anchors spaced at a maximum of 32 in. (813 mm) on center, provided on each jamb, based on the over-all frame height:

- i. Up to 60 in. (1524 mm).....3 anchors
- ii. Greater than 60 in. (1524 mm)
up to 90 in. (2286 mm).....4 anchors
- iii. Greater than 90 in. (2286 mm)
up to 96 in. (2438mm).....5 anchors
- iv. Greater than 96 in. (2438 mm).....5 anchors plus one for each 24 in. (610
mm) or fraction thereof, spaced at 24 in.
(610 mm) maximum between anchors

- d. Expansion Bolt Type

Prepare frame product for installation in existing masonry or concrete walls for expansion bolt type anchors. Provide a countersunk or dimpled hole for a 0.375 in. (9.5 mm) diameter flat head bolt and a spacer welded within the frame profile. Locate anchors a maximum of 6 in. (152 mm) from the top and bottom of the frame, with intermediate spacing at a maximum of 26 in. (660 mm) on center. Bolts and shields for such anchors provided and installed by others under Section 06 10 00.

- e. Other Anchor Types

Construct and provide frame product to be installed in pre-finished concrete, masonry or steel openings, with anchoring systems of suitable design and quantity as shown on the approved submittal drawings. Fasteners for such anchors shall be provided and installed by others under Section [03 30 00] [04 20 00].

A pre-finished opening may be one that is constructed as part of another assembly or system (e.g., precast concrete panel) and which requires anchors similar in performance to those covered by 2.03 B.15.b, and d.

16. Fabricate frame product installed in masonry walls with door openings greater than 48 in. (1219 mm) in width with a steel angle or channel stiffener factory welded into the head. Provide stiffeners not less than 0.093 in. (2.3 mm) in thickness, not longer than the door opening width. Stiffeners and frame product are not be used as lintels or load bearing members.
17. Attach grout guards fabricated from not less than 0.016 in. (0.4 mm) thick steel at hardware mortises on frame product to be grouted.
18. For all door openings in frame product provide a temporary steel spreader welded to the base of the jambs or mullions to serve as bracing during shipping, and handling. Spreaders are not be used for installation.
19. In-Fill Panels
 - a. Where specified or scheduled, provided frame product with in-fill panels secured to frame sections with removable steel stops.
 - b. For non-labeled frame product, construct in-fill panels from 0.032 in. (0.8 mm) minimum thick steel, of the same type specified for the frame product, laminated to each face of the manufacturer's standard solid backing.
 - c. For fire-rated frame product, construct in-fill panels from 0.032 in. (0.8 mm) minimum sheet steel, of the same type specified for the frame product, laminated to each face of a solid approved backing.

Refer to NAAMM HMMA 850, "Fire-Rated Hollow Metal Doors and Frames", for additional information.

20. Removable Glazing Stops

- a. Where specified, provide frame product with removable stops to secure glazing material or in-fill panels. Glazing materials are furnished and installed in the field by others, in accordance with glazing sizes and thickness shown in the contract documents.
- b. Fabricate removable steel channel glazing from not less than 0.032 in. (0.8 mm) thick, butted at corners and secured to the frame section using #6 minimum, corrosion resistant countersunk sheet metal screws.
- c. Treat the frame section underneath the glazing stops and the inside of the glazing stops for maximum paint adhesion and coat with a rust inhibitive primer prior to installation in the opening. Glazing stops fabricated from zinc-coated steel conforming to ASTM A 653/A 653M, A25 (ZF75) for interior frames, A60 (ZF180) or G60 (Z180) for exterior openings need not be primed on the inside.

2.04 MANUFACTURING TOLERANCES

The manufacturer of hollow metal doors and frame product is responsible only for the manufacturing tolerances listed in 2.04.A. The final clearances and relationships between door and frame depend on the setting of the frame (see Figure 4), and the hanging and adjustment of the door and hardware. See Sections 3.02 and 3.03.

- A. Maintain manufacturing tolerances within the following limits and in accordance with ANSI/NAAMM HMMA 841:
 1. Frame Product for Singles or Pairs of Doors
 - a. Width, measured between rabbets at the head: nominal opening width + 0.0625 in. (+ 1.5 mm), - 0.03125 in. (- 0.8 mm)
 - b. Height (total length of jamb rabbet): nominal opening height + 0.0625 in. (+ 1.5 mm), - 0.03125 in. (- 0.8 mm)

- c. Cross sectional profile dimensions (see Figure 2):
 - i. Face..... ± 0.0313 in. (0.8 mm)
 - ii. Stop..... ± 0.0313 in. (0.8 mm)
 - iii. Rabbet..... ± 0.0313 in. (0.8 mm)
 - iv. Depth..... ± 0.0625 in. (1.5 mm)
 - v. Throat..... ± 0.0938 in (2.3 mm)

Frame product overlapping walls to have throat dimension 1/8 in. (3.1 mm) greater than dimensioned wall thickness to accommodate irregularities in wall construction.

2. Doors

Tolerances for actual hollow metal door size are as follows:

- a. Width..... ± 0.0468 in. (1.2 mm)
- b. Height..... ± 0.0468 in. (1.2 mm)
- c. Thickness..... ± 0.0625 in. (1.5 mm)
- d. Perimeter Flatness..... 0.0625 in. (1.5 mm) maximum
- e. Surface Flatness..... 0.125 in (3.1 mm) maximum
- f. Twist..... 0.0625 in. (1.5 mm) maximum
- g. Squareness..... 0.0625 in. (1.5 mm) maximum

Surface flatness is applicable to doors up to 48" in width and 120" in height. Doors that exceed these measurements will possible exceed this tolerance and are not considered defective as long as they operate/function properly.

Hollow metal doors are undersized to fit the frame's door opening. Edge clearances are based upon individual manufacturer's designs.

3. Hardware

- a. Cutouts.....Template dimensions $+0.0156$ in. (0.4 mm), - 0
- b. Location..... ± 0.0313 in. (0.8 mm)
- c. Between hinge centerlines..... ± 0.0156 in (0.4 mm)
- d. Face cutout for hinges..... $+ 0.0625$ in.(1.5 mm) – 0
- e. Mortise depth of reinforcement..... ± 0.0156 in (0.4 mm)

These tolerances provide a reasonable guideline for manufacturing of hollow metal products. However, it should be noted that the cumulative effect of manufacturing tolerances at or near their maximum levels could have an effect on operating clearances. Tolerance buildup occurs when several tolerances are at or near their maximums. Care should be taken to keep each of these tolerances as close to zero as possible.

2.05 HARDWARE LOCATIONS

- A. The location of hardware on doors and frame product shall be as listed below. All dimensions, except the hinge locations, are referenced from the floor as defined in Section 3.03.B.3.

When hollow metal frame products are specified for use with doors to be furnished by others, hardware preparations on the doors are normally governed by the location on the frames as stated, in 2.05 A.

1. Hinges

- a. Top..... 5 in. (127 mm) from underside of frame rabbet at door opening to top of hinge
- b. Bottom..... 10 in. (254 mm) from floor to bottom of hinge

- c. Intermediate..... Centered between top and bottom hinges
- d. On dutch doors..... 5 in. (127 mm) from underside of frame rabet at door opening to top of upper hinge; 10 in. (254 mm) from floor to bottom of lower hinge; and 5 in. (127 mm) from split line to top and bottom of lower and upper intermediate hinges, respectively
- 2. Locks and latches.....38 in. (965 mm) to centerline of knob or lever shaft
- 3. Deadlocks.....46 in. (1168 mm) to centerline of cylinder
- 4. Exit hardware.....Centerline of cross bar as shown on hardware template or as shown on approved contract documents..
- 5. Door pulls.....42 in. (1066 mm) to center of grip
- 6. Push/pull bars.....42 in. (1066 mm) to centerline of bar
- 7. Hospital latch arm pulls.....45 in. (1143 mm) to centerline
- 8. Push plates.....46 in. (1168 mm) to centerline of plate
- 9. Roller latches.....46 in. (1168 mm) to centerline of latch

The hardware locations listed in this specification reflects HMMA’s 830, “Hardware Selection for Hollow Metal Doors and Frames” and 831, “Recommended Hardware Locations for Hollow Metal Doors and Frames”. However, specific hardware and/or individual door frame manufacturers’ designs may require different locations.

2.06 FINISH

- A. After fabrication, fill and sand all tool marks and surface imperfections as required to make face sheets, continuously welded vertical door edges and weld joints free from irregularities and dressed smooth.
- B. After appropriate metal preparation to ensure maximum paint adhesion, provide a factory applied rust inhibitive direct to metal (DTM) primer coating to all exposed surfaces of door and frame product manufactured from cold-rolled, hot-rolled, or G60 (Z180) zinc-coated. Meet the performance requirements of Section 1.05.C.
- C. All primer must be cured prior to shipment.

PART 3 - EXECUTION

3.01 SITE STORAGE AND PROTECTION OF MATERIALS

Correct site storage and protection are essential to proper performance of doors and frame product. The requirements for proper storage are given in the following Section. However, it is important to recognize that these are not the responsibility of the hollow metal manufacturer. For this reason the requirements for storage and protection of hollow metal doors and frame product should be included in the Section of the specification where installation work is specified. For additional information regarding installation see NAAMM HMMA 840, “Guide Specification for Installation and Storage of Hollow Metal Doors and Frames”.

- A. Responsibilities of the contractor responsible for receiving hollow metal door and frame product;
 - 1. Remove wraps or covers upon delivery at the building site and ensure that any scratches or disfigurement caused by shipping or handling are promptly cleaned and touched up with a rust inhibitive ‘Direct to Metal’ (DTM) primer.
 - 2. Ensure that materials are properly stored on planks or dunnage in a dry location. Store doors and frame product in a vertical position, spaced by blocking. Figure 3 illustrates recommended storage positioning. Cover materials to protect them from damage but in such a manner as to permit air circulation.

3.02 INSTALLATION

Correct installation is essential to the proper performance of doors and frame product. The requirements for proper installation are given in the following Sections. However it is important to recognize that installation is not the responsibility of the hollow metal manufacturer. For this reason the requirements for installation should be included in Sections 03 30 00, 04 20 00, 06 11 00 and/or 09 20 00 of the project specifications, as appropriate. For additional information see NAAMM HMMA 840, "Guide Specifications for Installation and Storage of Hollow Metal Doors and Frames"..

A. The installer is responsible for performing the following;:

1. Prior to installation;

- a. Check the area of floor on which the frame product is to be installed, and within the path of the door swing, for flatness and correct if necessary.
- b. Check doors and frame product for correct size, swing, fire rating and opening number. If product does not comply with contract documents, do not install and contact the supplier.
- c. Isolate and protect all interior surfaces of perimeter frame product sections to be installed in masonry or concrete walls from grout and antifreeze agents.

The drawbacks and benefits associated with the use of water based masonry grouts, with or without antifreeze agents, should be carefully weighed during the detailing and specification process. Grouting of mullions and other closed sections is not recommended, and plaster based grouts should not be used. Refer to NAAMM HMMA Tech Note, HMMA 820 TN01-03, "Grouting Hollow Metal Frames", included as Appendix 2, for further guidance.

- d. Remove temporary spreaders.
- e. Refinish to match original, any marks caused by spreader removal.

2. During the setting of frame product check and correct as necessary for opening width, opening height, squareness, alignment, twist and plumbness. Maintain installation tolerances within the following limits.

- a. Opening Width..... measured from rabbet to rabbet at top, middle and bottom of frame + 0.0625 in (1.5 mm), - 0.0313 in (0.8 mm)
- b. Opening Height..... measured vertically between the frame head rabbet and top of floor or bottom of frame minus jamb extension at each jamb and across the head; + 0.0625 in (1.5 mm), - 0.0313 in (0.8 mm)
- c. Squareness..... measured at rabbet on a line from jamb, perpendicular to frame head; not to exceed 0.0625 in (1.5 mm)
- d. Alignment..... measured at jambs on a horizontal line parallel to the plane of the face; not to exceed 0.0625 in (1.5 mm)
- e. Twist..... measured at opposite face corners of jambs on parallel lines perpendicular to the plane of the door rabbet; not to exceed 0.0625 in (1.5 mm)
- f. Plumbness..... measured at the jambs on a perpendicular line from the head to the floor; not to exceed 0.0625 in (1.5 mm)

The above tolerances provide a reasonable guideline for proper installation of hollow metal frame product. However, it should be noted that the cumulative affect of the installation tolerances at or near their maximum levels could result in sufficient misalignment to prevent the door from functioning properly. Installers should be careful not to create a tolerance buildup. Tolerance buildup occurs when several tolerances are at or near their maximums.

3. The details in Figure 4 illustrate the method of measuring the above specified tolerances.
4. Grout guards and junction boxes are intended to protect hardware mortises and tapped holes from masonry grout of 4 in. (101 mm) maximum slump consistency which is hand troweled in place. If a lighter consistency grout (greater than 4 in. (101 mm) slump when tested in accordance with ASTM C 143/C 143M) is to be used, special precautions must be taken in the field by the installer to protect the aforementioned.
5. Frame products are not intended or designed to act as forms for grout or concrete. Take precautions otherwise to ensure that frames are not deformed or damaged by the hydraulic forces that occur during this process.
6. Keep steel surfaces free of grout, tar, and/or other bonding materials or sealers. Promptly clean grout, tar, and/or other bonding materials or sealers off of doors and frame product. If the primer is removed, damaged or negatively affected by this process, promptly finished smooth, cleaned, treated for maximum paint adhesion and touched up with a rust inhibitive primer comparable to and compatible with the shop applied primer and finish paint specified in Section 09 90 00. All touch-up primer and finish paint must be formulated for Direct to Metal (DTM) application.
7. Install labeled fire doors and frame product in accordance with the terms of their listings, ANSI/ NFPA 80 or the local Authority Having Jurisdiction.
8. Maintain proper door edge clearances in accordance with Section 3.03, except for special conditions otherwise noted. Where necessary, metal hinge shims, furnished by the installer, are permitted to maintain clearances.
9. Exposed hollow metal surfaces which have been scratched or otherwise marred during installation, cleaning, and/or field welding, shall promptly be finished smooth, cleaned, treated for maximum paint adhesion and touched up with a rust inhibitive primer comparable to and compatible with the shop applied primer and finish paint specified in Section 09 90 00. All touch-up primer and finish paint must be formulated for Direct to Metal (DTM) application.
10. Install hardware in accordance with hardware manufacturer's templates and instructions.
11. Finish paint in accordance with Section 09 90 00.
See NAAMM HMMA 840 TN01, Painting Hollow Metal Products.
12. Install door silencers.
13. Install glazing materials in accordance with Section 08 80 00.

3.03 CLEARANCES

- A. Ensure that the edge clearance for swinging hollow metal doors provides for the functional operation of the assembly and does not exceed the following:
 1. Between doors and frame product at head and jamb.....0.125 in (3.1 mm) +/- 0.0625 in (1.5 mm)
 2. Between edges of pairs of doors.....0.125 in (3.1 mm) +/- 0.0625 in (1.5 mm)
- B. Floor clearance for fire-protection rated swinging hollow metal doors shall not exceed 0.75 in (19.0 mm). Floor clearance shall be provided for the functional operation of all swinging hollow metal doors and shall not be less than 0.125 in (3.1 mm).

The architect must define the distance from top of the floor/finished floor to top of floor covering so appropriate undercuts can be provided. Floor/Finish Floor is defined as the top of the concrete or structural slab. HMMA uses the term "top of floor covering" to describe the NFPA term "nominal surface of floor covering". Refer to HMMA's Tech Note, HMMA 810 TN01-03, "Defining Undercuts", included as Appendix 3 for further guidance.

END OF SECTION

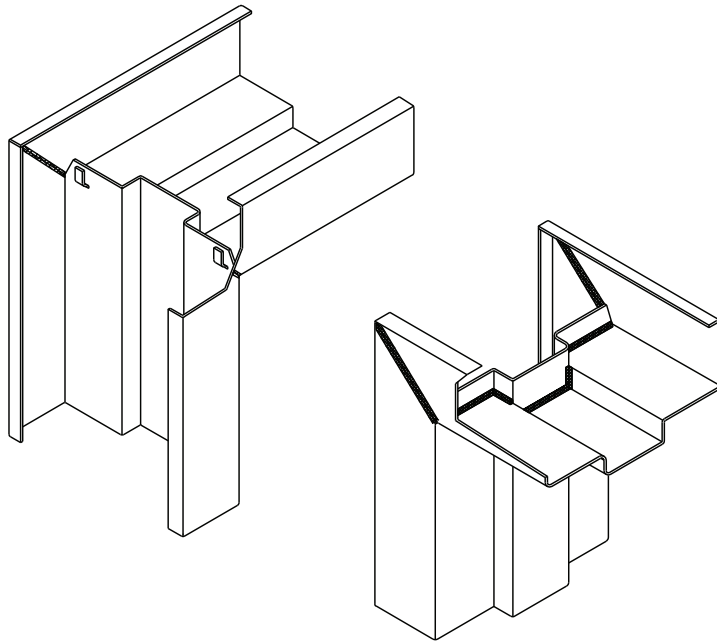

CONTINUOUS WELD CORNER JOINT

**NOTE: Joint design may vary; see HMMA-820, “Hollow Metal Frames”
for representative corner joint details**

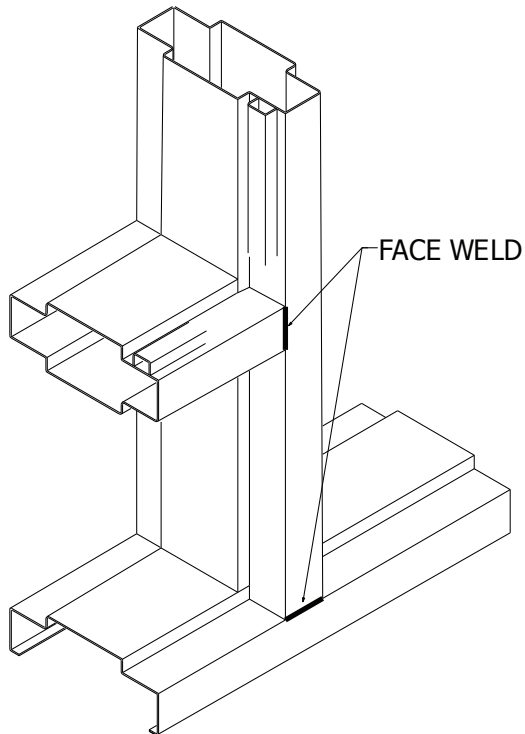

BUTTED AND FACE WELDED JOINTS

FIGURE #1

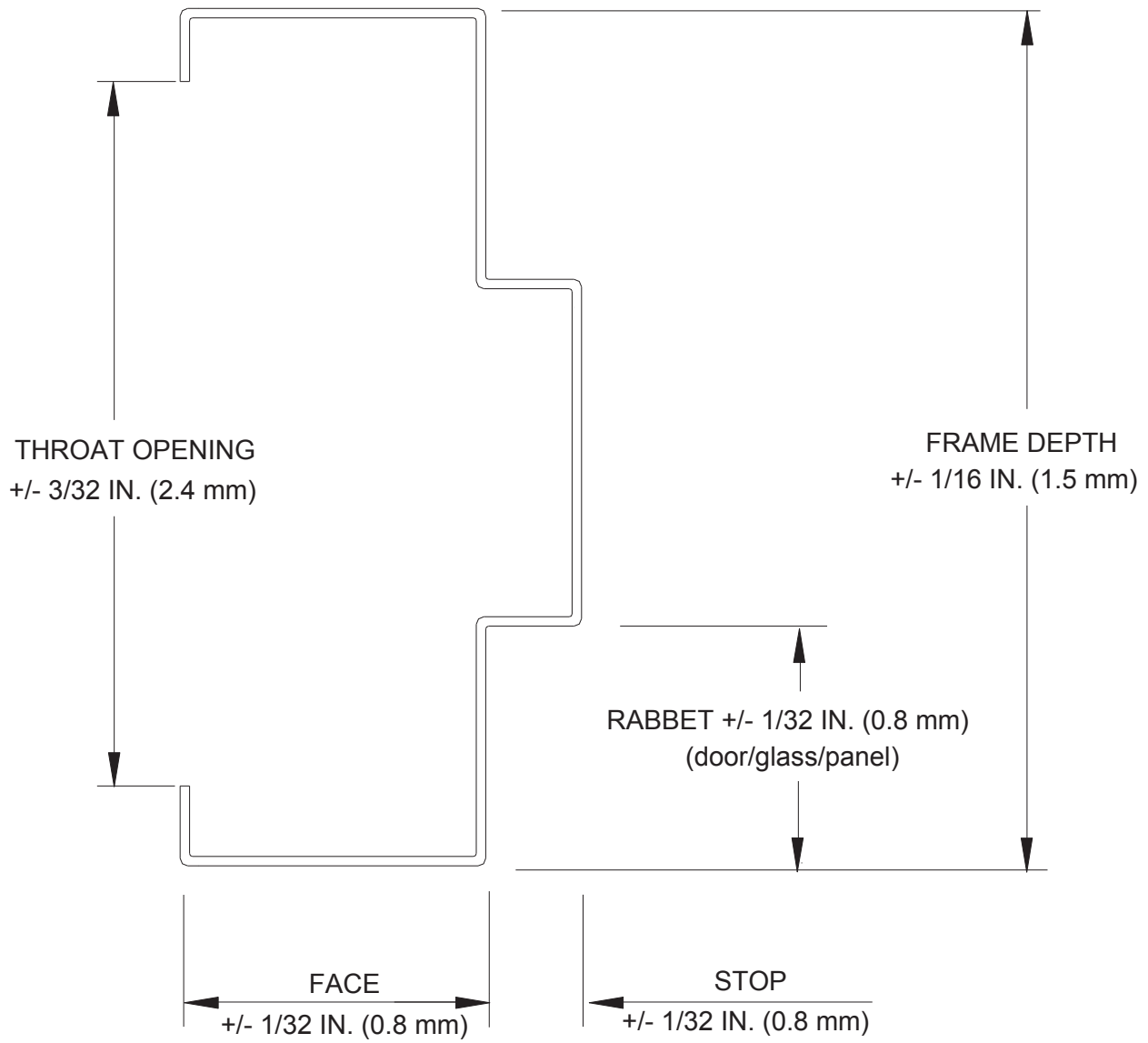

Figure #2
Sectional Profile Tolerances

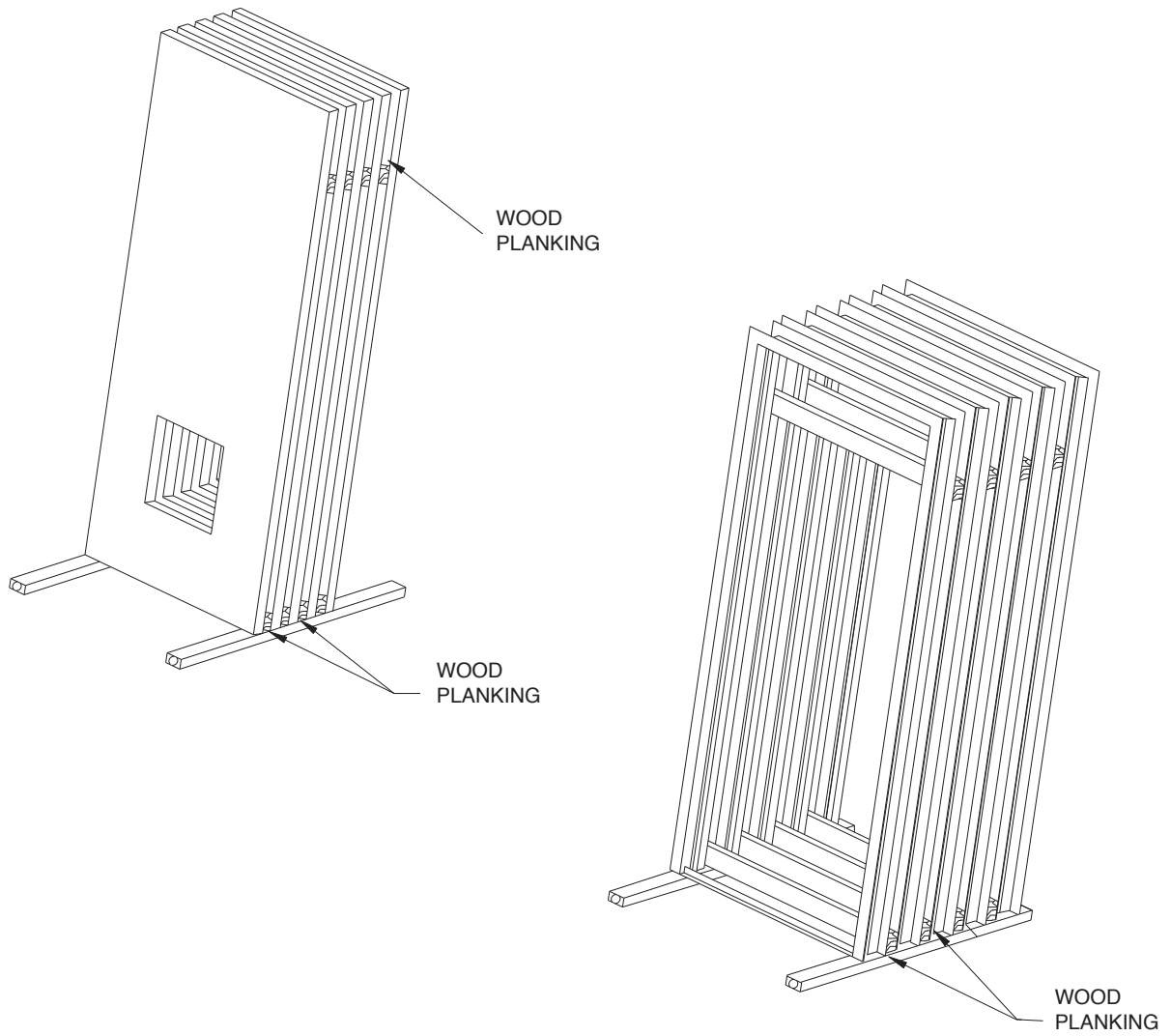

Figure #3
Recommended Storage

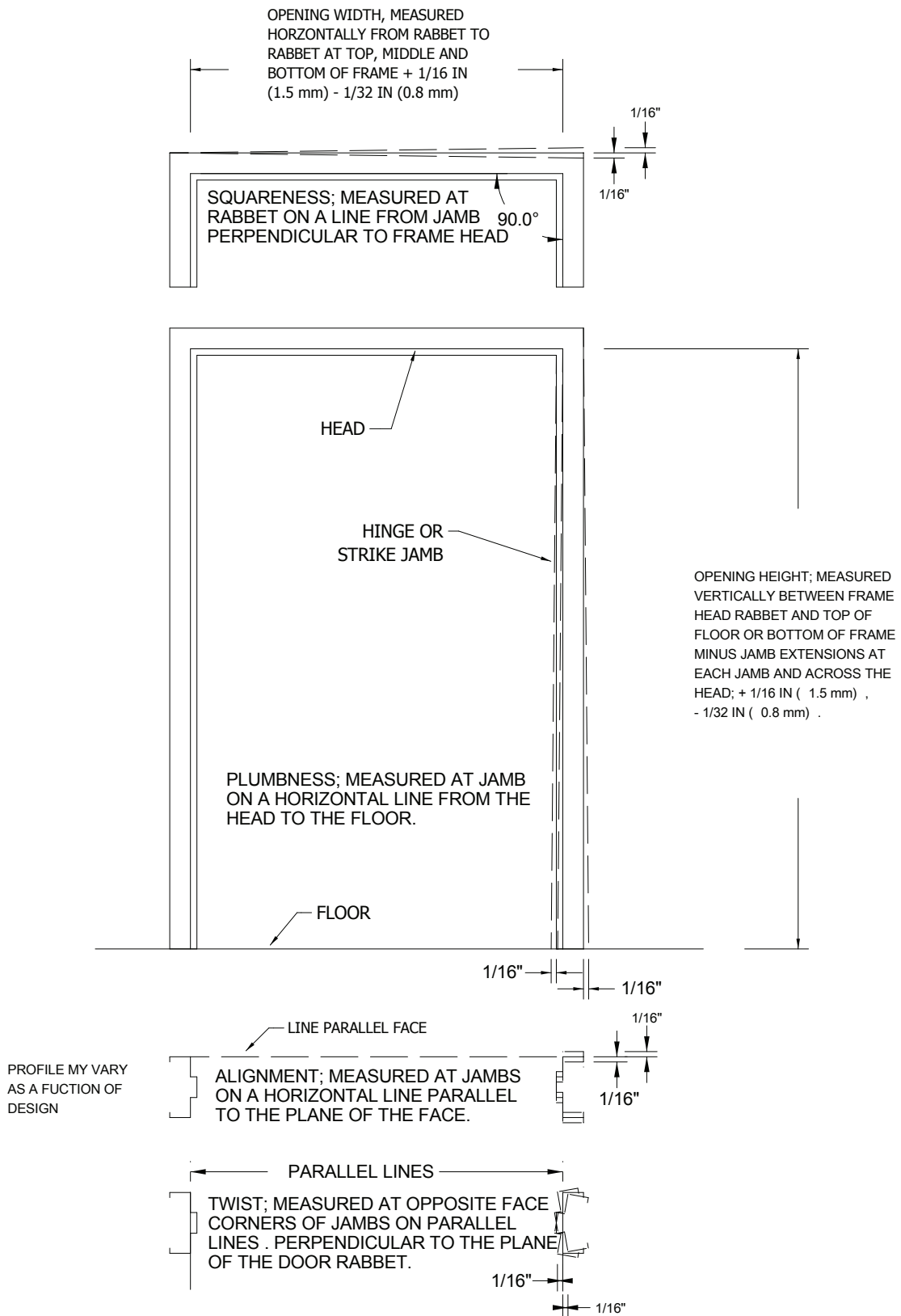

Figure #4
Installation Tolerances

APPENDIX 1
(Not part of the Standard)

NAAMM/HMMA 803-08 - STEEL TABLES

Prior to 1970, sheet steel was referred to by gage. ASTM and ANSI currently do not list gage numbers in their standards. Like many generic terms, gage (or gauge) is ingrained in many vocabularies and is misunderstood as a term for thickness. NAAMM is publishing this minimum thickness table to be used instead of discontinued gage numbers.

The decimal inch values shown were taken from the Underwriters Laboratories, Inc. publication for gage number and equivalent thickness. Corresponding metric values are included for reference purposes only.

MINIMUM THICKNESS		
(Uncoated Steel Sheet)		
Gage	Decimal Inch	mm
4	0.214	5.43
5	0.199	5.05
6	0.184	4.67
7	0.167	4.24
8	0.152	3.86
10	0.123	3.12
12	0.093	2.36
14	0.067	1.70
16	0.053	1.34
18	0.042	1.06
20	0.032	0.81
22	0.026	0.66
24	0.020	0.50
26	0.016	0.40
28	0.013	0.33

CONVERSION		
Fractional Inch	Decimal Inch	mm
	1.000	25.40
15/16	0.937	23.81
7/8	0.875	22.22
13/16	0.812	20.63
3/4	0.750	19.05
11/16	0.687	17.46
5/8	0.625	15.87
9/16	0.562	14.28
1/2	0.500	12.70
7/16	0.437	11.11
3/8	0.375	9.52
5/16	0.312	7.93
1/4	0.250	6.35
3/16	0.187	4.76
1/8	0.125	3.17
1/16	0.062	1.58

DISCLAIMER

This sheet was developed by representative members of the Hollow Metal Manufacturers Association Division (HMMA) of the National Association of Architectural Metal Manufacturers (NAAMM) to provide their opinion and guidance on minimum thickness and corresponding metric equivalents used for hollow metal doors and frames. This sheet contains advisory information only and is published as a public service by the HMMA Division.

NAAMM AND ITS HMMA DIVISION DISCLAIM ALL LIABILITY OF ANY KIND FOR THE USE, APPLICATION OR ADAPTATION OF MATERIAL SHOWN ON THIS SHEET

APPENDIX 2
(Not part of the Standard)

GROUTING HOLLOW METAL FRAMES
HMMA-820 TN01-03

Grout, when used in accordance with industry guidelines can improve frame durability, sound deadening and, depending on wall construction, increases frame anchorage strength. Grouting of the frame does not increase door durability, nor is it required for fire-rated frames. For most commercial applications, grouting of mullions and other closed sections is not recommended.

For applications covered by ANSI/NAAMM HMMA 862, "Guide Specifications for Commercial Security Hollow Metal Doors and Frames" and ANSI/NAAMM HMMA 863, "Guide Specifications for Detention Security Hollow Metal Doors and Frames", the standards require that "frame jambs shall be fully grouted to provide added security protection against battering, wedging, spreading, and other means of forcing open the door".

Grout is a water-based product. If not used properly, it can destroy the opening in a very short time. Grout can be either "mortar", which is a masonry mixture of lime, cement, sand and water, or "plaster", a gypsum-based product.

Plaster grout dries with exposure to air. When a frame member is filled solid with plaster grout, only those areas exposed to air will dry and harden, while the center remains wet (uncured). The water remaining in the plaster grout can rust the frame from the inside.

Mortar grout cures by chemical reaction and hardens throughout. Use mortar grout.

Frames are not designed to act as forms for grout. Grout must have a maximum 4 in. slump and be hand troweled in place. Bracing of the frame may be necessary prior to grouting to prevent sagging of the header or bowing of the jamb due to weight or pressure of the grout. Grout should not be installed after gypsum wallboard is installed, as the liquid within the grout will deteriorate the wallboard.

When dictated by temperatures, anti-freezing agents for mortar may be recommended by specifications. These agents can adversely affect metal and all surfaces in contact with grout must be coated with a corrosion resistant material.

It is recommended that the contractor be responsible for the grouting and for any additional barrier coating. It is also the contractor's responsibility to use care in the application of the grout.

APPENDIX 3 (Not part of the Standard) DEFINING UNDERCUTS HMMA-810 TN01-03

Review of established definitions.

1. **“ACTUAL DOOR HEIGHT”** - The door opening height minus top clearance and undercut.
2. **“DOOR OPENING HEIGHT”** - The distance measured vertically between the frame head rabbet and top of floor or bottom of frame minus jamb extension.
3. **“FINISHED FLOOR”** - See “Floor”
4. **“FLOOR”** - The top of the concrete or structural slab.
5. **“FLOOR CLEARANCE”** - The distance between the bottom of the door and the top of the material directly below the door. This varies with application, such as concrete, any floor covering and/or a threshold.
6. **“FLOOR COVERING”** - Any material applied on top of the floor that extends under the door in its closed position or under the door as it swings to its fully open position.
7. **“UNDERCUT”** - The distance between the bottom of door and the bottom of frame. The formula in which to determine Undercut is derived by adding the total sum of the following (Floor Clearance + Floor Covering Thickness + Threshold Height (assuming the threshold is mounted on top of the floor covering) + Jamb Extensions Height).
8. **“JAMB EXTENSIONS”** - That portion of a jamb or mullion which extends below the level of the floor.

Typically frames are intended to be installed directly on the floor. When no floor coverings or thresholds are used, the dimension for “Undercut” is the same as for “Floor Clearance”. See Figure # 1.

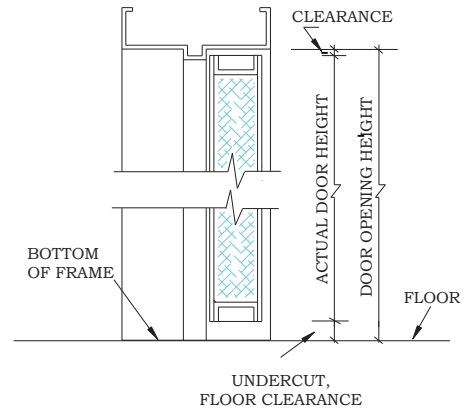

Figure # 1

Floor coverings; such as carpet, resilient or ceramic tile, are typically installed on top of the floor, fitted around the frame, and under the door. In this situation, the formula for figuring Undercut is the total of the Floor Clearance + Floor Covering Thickness. See Figure # 2.

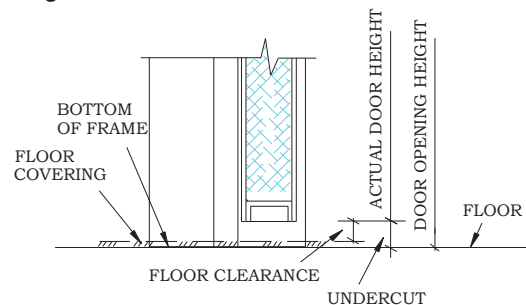

Figure # 2

When a threshold is used, it is installed on top of the floor or floor covering, fitted around the frame and under the door. Again the formula for figuring “Undercut” changes. Undercut is the total of the Floor Clearance + Threshold Height + Floor Covering Thickness. See Figure # 3.

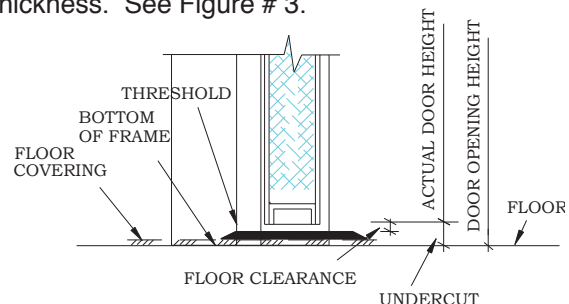

Figure # 3

In situations with specialized floors such as thick ceramic tile or terrazzo, the frame is typically installed prior to the installation of the floor.

One method is to install the frame with adjustable floor anchors or for the frame to be installed on a block or shim. This allows the frame to be positioned, as required, to accommodate the floor height. See Figures # 4A and 4B. Both illustrate a raised frame condition in which the bottom of frame is positioned to be directly on top of the floor after the floor is installed. In this situation, the dimension measured for Undercut is also the same as Floor Clearance.

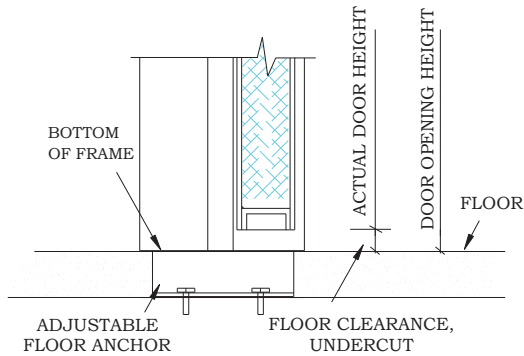

Figure # 4A

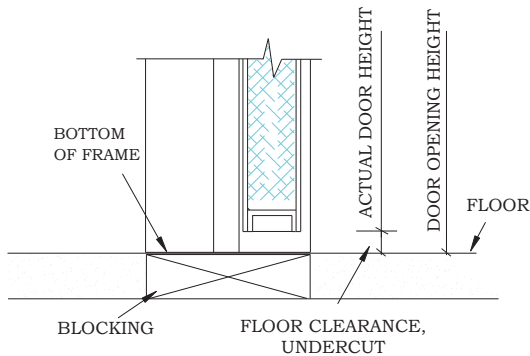

Figure # 4B

Another method, called “below floor installation”, is to install the frame directly on the rough slab. After the frame is installed, the floor is then installed around the frame. That portion of the frame is covered by the floor and is called jamb extensions. The formula for figuring “Undercut” is the total of the Floor Clearance + Jamb Extensions. See Figures # 5A and 5B.

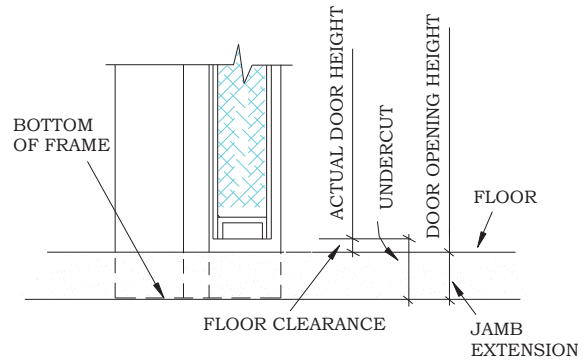

Figure # 5A

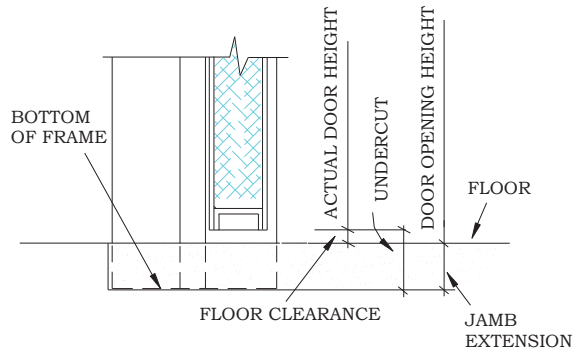

Figure # 5B

The Architect/Designer must be very specific within specifications and contract drawings, which should include detailed drawings illustrating conditions for each floor, including thicknesses and materials. These drawings should designate the height at which the hollow metal frame should be set. Thresholds and hardware items requiring specific floor clearances shall be listed in the hardware schedule, which allows the door and frame manufacturer to properly size each opening.

Within the door and frame industry, both the Hollow Metal Manufacturers Association (HMMA) a division of the National Association of Architectural Metal Manufacturers (NAAMM) and the Steel Door Institute (SDI), publish recommended clearances. In addition, the National Fire Protection Association (NFPA) Publication 80, “Standard for Fire Doors and Fire Windows”, regulates the installation and maintenance of labeled openings, and lists several different scenarios consisting of different floor materials and the maximum clearance under the bottoms of doors.

APPENDIX 4
(Not part of the Standard)
STANDARDS DEVELOPMENT ORGANIZATIONS

ANSI	American National Standards Institute, Inc. 11 West 42nd Street New York, NY 10036 Tel: (212) 642-4900 Website: www.ansi.org
ASTM	ASTM International 100 Barr Harbor Drive West Conshohocken, PA 19428-2959 Tel: (610) 832-9585 Website: www.astm.org
ICC	International Code Council 500 New Jersey Avenue NW 6th Floor Washington, DC 20001-2070 Tel: 1 (888) 422-7233 Website: www.iccsafe.org
NAAMM	National Association of Architectural Metal Manufacturers 800 Roosevelt Road Building C, Suite 312 Glen Ellyn, IL 60137 Tel: (630) 942-6591 Website: www.naamm.org
NFPA	National Fire Protection Association 1 Batterymarch Park P.O. Box 9101 Quincy, MA 02269 Tel: (617) 770-3000 Website: www.nfpa.org
UL	Underwriters Laboratories, Inc. 333 Pfingsten Road Northbrook, Illinois 60062 Tel: (847) 272-8800 Website: www.ul.com

RECOMMENDED GUIDE SPECIFICATIONS FOR HOLLOW METAL DOORS AND FRAMES

HMMA 860- Hollow Metal Doors and Frames

ANSI/NAAMM

HMMA 861- Commercial Hollow Metal Doors and Frames

ANSI/NAAMM

HMMA 862- Commercial Security Hollow Metal Doors and Frames

ANSI/NAAMM

HMMA 863- Detention Security Hollow Metal Doors and Frames

NAAMM

HMMA 865- Sound Control Hollow Metal Door and Frame Assemblies

ANSI/NAAMM

HMMA 866- Stainless Steel Hollow Metal Doors and Frames

ANSI/NAAMM

HMMA 867- Commercial Laminated Core Hollow Metal Doors and Frames

RELATED HMMA DOCUMENTS

HMMA 800- Introduction to Hollow Metal

ANSI/NAAMM

HMMA 801- Glossary of Terms for Hollow Metal Doors and Frames

HMMA 802- Manufacturing of Hollow Metal Doors and Frames

HMMA 803- Steel Tables

HMMA 810- Hollow Metal Doors

HMMA 820- Hollow Metal Frames

HMMA 830- Hardware Selection for Hollow Metal Doors and Frames

HMMA 831- Recommended Hardware Locations for Hollow Metal Doors and Frames

HMMA840- Installation and Storage of Hollow Metal Doors and Frames

ANSI/NAAMM

HMMA 841- Tolerances and Clearances for Commercial Hollow Metal Doors and Frames

HMMA 850- Fire-Rated Hollow Metal Doors and Frames

HMMA 890- Technical Summary

HMMA 810TN01- Defining Undercuts

HMMA 820TN01- Grouting Hollow Metal Frames

HMMA 820TN02- Continuously Welded Frames

HMMA 820TN03- Guidelines for Glazing Hollow Metal Transoms, Sidelights and Windows

HMMA 840TN01- Painting Hollow Metal Products

HMMA 840TN02- Maintenance of Installed Hollow Metal Products